

PF-2012-02-01 SPECIFICATION SHEET PUMP PACKAGE SYSTEM

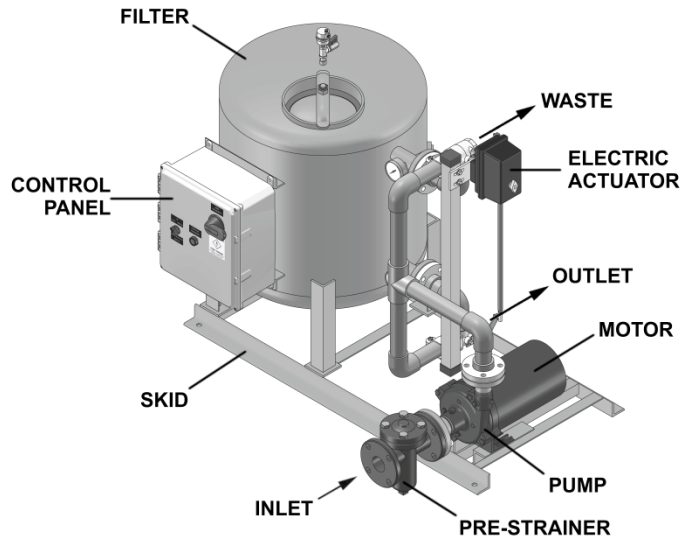

Features:

- Removes particulate 10 microns and finer
- 75 psi working pressure
- Fully assembled skid package
- One year limited warranty
- Inlet/Outlet pressure gauges

Options:

- Higher pressure ratings
- ASME code stamped vessel

SYSTEM COMPONENTS

| SPECIFICATIONS | PF-2012-02-01 |
|--------------------------|---------------|
| Flow Rate | 15 GPM |
| Filtration Area | 0.78 sq ft |
| Valve Size | 1" |
| System Inlet Connection | 2" flng |
| System Outlet Connection | 1" fpt |
| Waste Connection | 1" fpt |
| Backwash Connection | N/A |
| Pump Motor | 1 HP |
| Est. Weight, Dry | 400 lbs |
| Est. Weight, Operating | 450 lbs |

Filter Vessel :

- Non-code stainless steel vessel
- Epoxy coated carbon steel hand hole covers
- Manual & auto air vents
- Pressure gauge
- Industrial grade 3-way ball valves

Electrical Controls :

- UL labeled control panel
- Door disconnect switch
- Motor starter with Short-circuit/overload protection
- Electric actuator
- Local/Off/Remote Switch
- Pump Status/Trip Dry Contact Signals

Pump :

- Centrifugal pump
- TEFC motor
- Cast iron pre-strainer

Backwash Controls :

- Pressure differential switch
- 24 Hour time clock
- Manual push button
- Adjustable solid state timer

Skid :

- Fusion-bond polyester coated carbon steel

Interconnecting Pipe :

- Sch.80 PVC piping

*Shipping weight includes media

NOTES: UNLESS OTHERWISE SPECIFIED

1. DIMENSIONS ARE IN INCHES

2. DIMENSIONS MAY VARY SLIGHTLY - DO NOT USE FOR CONSTRUCTION

| REVISIONS | | | |
|-----------|-------------|------|----------|
| REV | DESCRIPTION | DATE | APPROVED |
| - | | | |

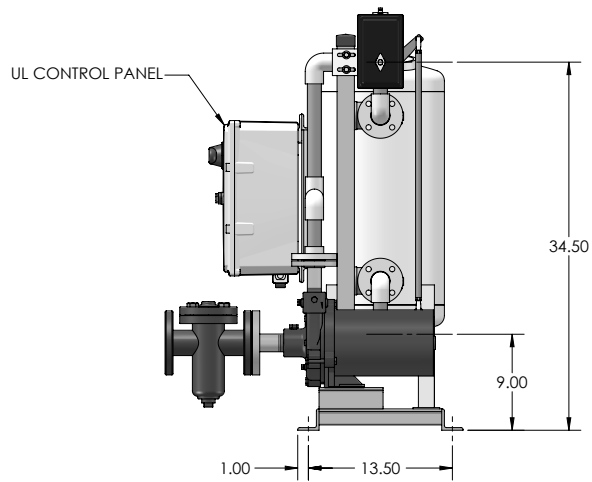
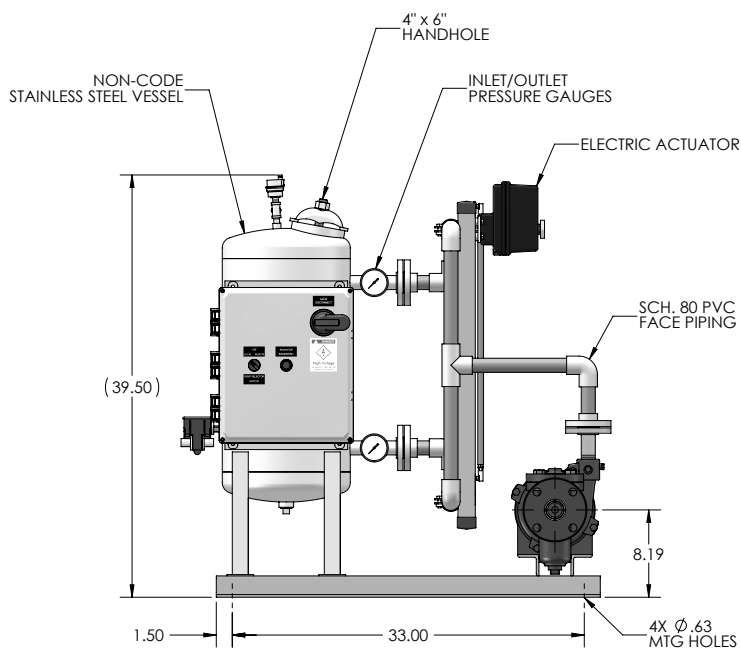
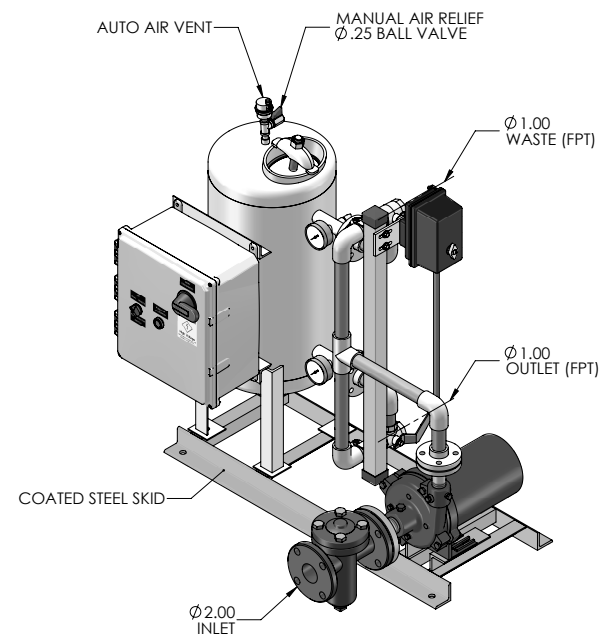
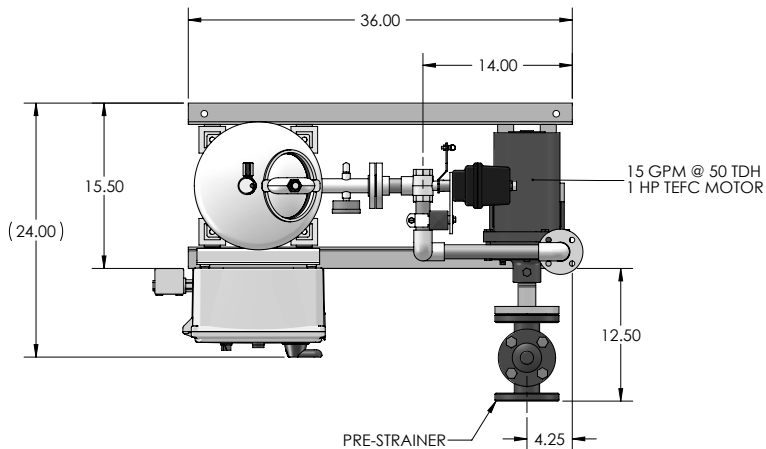

| | | | |
|--|---|-------------------|--|
| PROPRIETARY AND CONFIDENTIAL THE INFORMATION CONTAINED IN THIS DRAWING IS THE SOLE PROPERTY OF PUROFLUX CORPORATION. ANY REPRODUCTION IN PART OR AS A WHOLE WITHOUT THE WRITTEN PERMISSION OF PUROFLUX CORPORATION IS PROHIBITED. | PF-2012-02-01: FILTER SYSTEM SOURCE WATER BACKWASH | |  PUROFLUX CORPORATION |
| | SIZE C DWG NO. 201-0268 | REV - | |
| DRAWN C. NIELSEN | RELEASE DATE 7-19-19 | SCALE NONE | SHEET 1 OF 1 |

| REVISIONS | | | |
|-----------|-------------|------|----------|
| REV | DESCRIPTION | DATE | APPROVED |
| | | | |

| PUMP MOTOR FULL LOAD AMPS (3Ø, 60Hz) | | | | |
|---|-----------|-----------|-----------|-----------|
| MOTOR HP | 208 VOLTS | 230 VOLTS | 460 VOLTS | 575 VOLTS |
| 1 | 3.22 | 2.8 | 1.4 | 1.12 |
| 1.5 | 5.01 | 4.36 | 2.18 | 1.94 |
| 2 | 6.44 | 5.6 | 2.8 | 2.24 |
| 3 | 9.59 | 8.34 | 4.17 | 3.34 |
| 5 | 15.5 | 13.5 | 5.76 | 5.41 |
| 7.5 | 22.4 | 19.5 | 9.79 | 7.81 |
| 10 | 29.2 | 25.4 | 12.7 | 10.1 |
| 15 | 45.1 | 39.2 | 19.6 | 15.7 |
| 20 | 58.9 | 51.2 | 25.6 | 20.5 |

FULL LOAD CURRENTS LISTED ABOVE ARE "AVERAGE VALUES" FOR HORSEPOWER RATED MOTORS OF SEVERAL MANUFACTURERS. THE RATED FULL LOAD CURRENT SHOWN ON THE MOTOR NAMEPLATE MAY VARY BY MANUFACTURER.

- NOTES**
- NOTES: UNLESS OTHERWISE SPECIFIED
- BRANCH CIRCUIT PROTECTION SUPPLIED BY OTHERS
 - PANEL U.L. LISTED AND LABELED
 - DASHED LINES INDICATE FIELD WIRING
 - SWITCH OPERATION
 "LOCAL" - REMOTE STOP/START OVERRIDE
 "OFF" - FILTER "OFF"
 "AUTO" - FILTER ON/OFF VIA REMOTE STOP/STOP

WARNING

If an overload or fault current interruption occurs, circuits must be checked to determine the cause of the interruption. If a fault condition exists, the current carrying components should be examined and replaced if damaged, and the integral current sensors must be replaced to reduce the risk of fire or electric shock.

CAUTION - RISK OF ELECTRICAL SHOCK

More than one disconnect switch may be required to de-energize the equipment before servicing.

WARNING - RISK OF FIRE OR ELECTRIC SHOCK

The opening of the branch circuit protective device may be an indication that a fault current has been interrupted. All current carrying parts and other components protected by this device should be examined and replaced if damaged. If burnout of a current element of an overload relay occurs, the complete overload relay must be replaced.

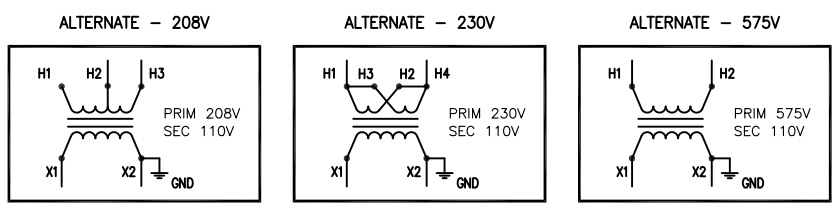
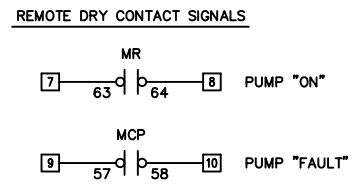
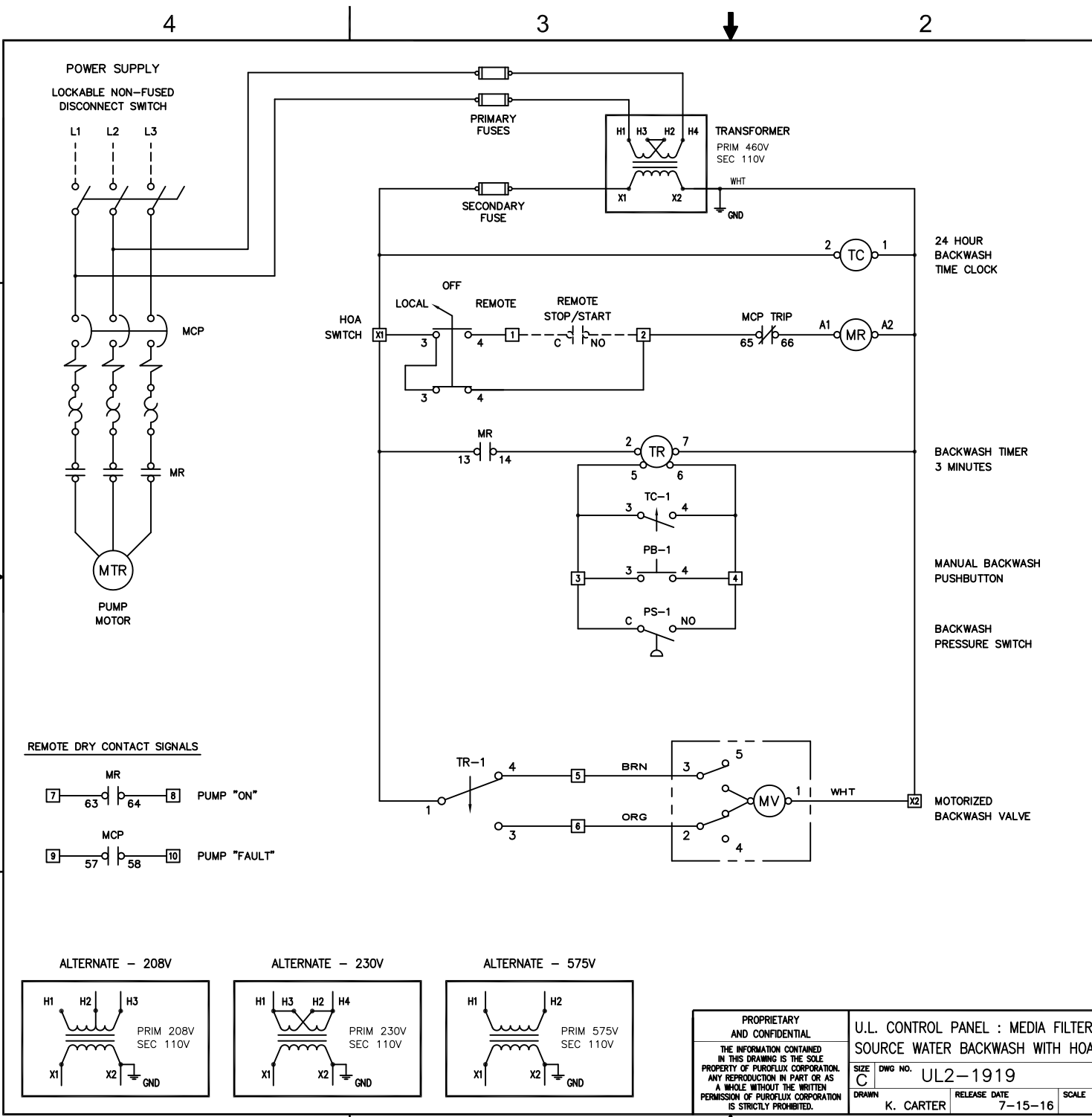

PROPRIETARY AND CONFIDENTIAL

THE INFORMATION CONTAINED IN THIS DRAWING IS THE SOLE PROPERTY OF PUROFLUX CORPORATION. ANY REPRODUCTION IN PART OR AS A WHOLE WITHOUT THE WRITTEN PERMISSION OF PUROFLUX CORPORATION IS STRICTLY PROHIBITED.

U.L. CONTROL PANEL : MEDIA FILTER SOURCE WATER BACKWASH WITH HOA

SIZE DWG NO. UL2-1919

REV A

DRAWN K. CARTER

RELEASE DATE 7-15-16

SCALE NONE

PUROFLUX CORPORATION

WWW.PUROFLUX.COM

SHEET 1 OF 1