

NOTES: UNLESS OTHERWISE SPECIFIED

1. DIMENSIONS ARE IN INCHES
2. DIMENSIONS MAY VARY SLIGHTLY - DO NOT USE FOR CONSTRUCTION
3. SEPARATOR SYSTEM IS RATED FOR 150 PSI WORKING PRESSURE

REVISIONS			
REV	DESCRIPTION	DATE	APPROVED
C	REVISED PANEL	5-29-19	S.R.

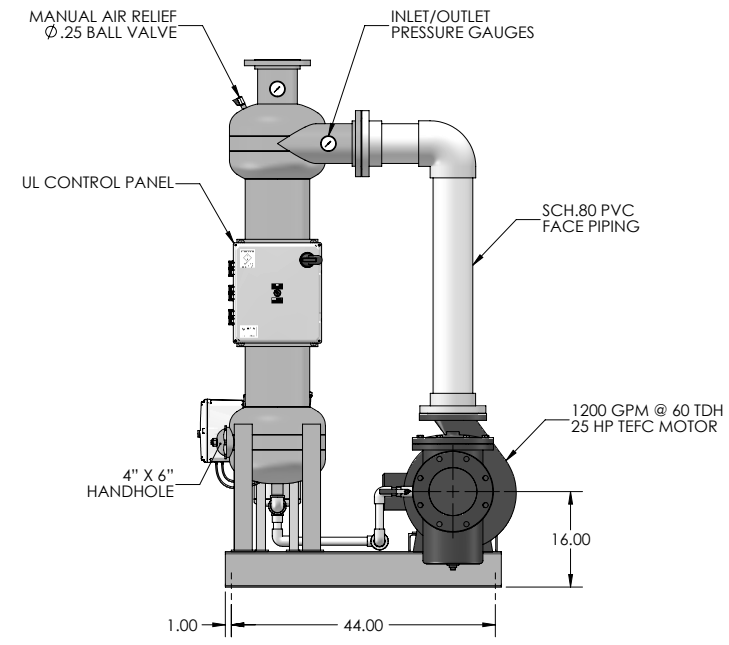
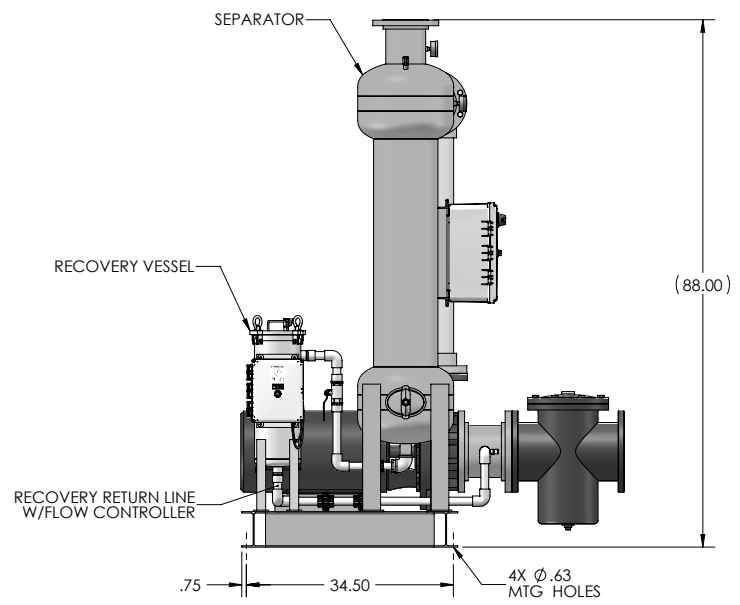
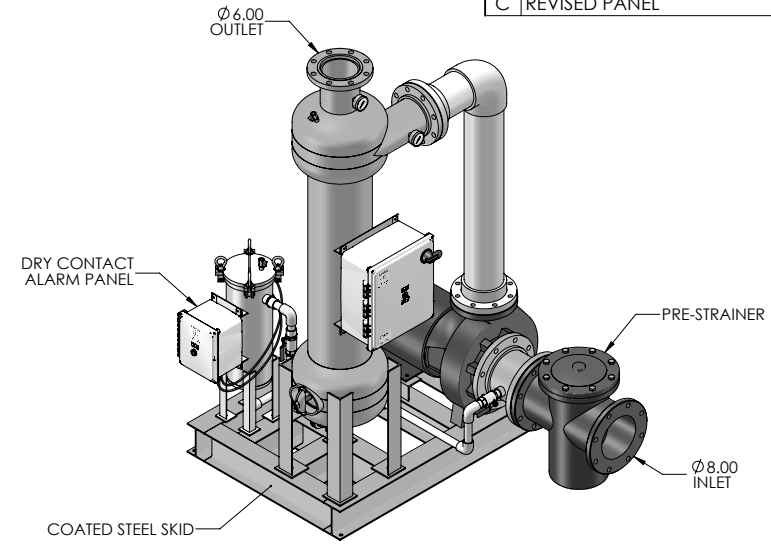
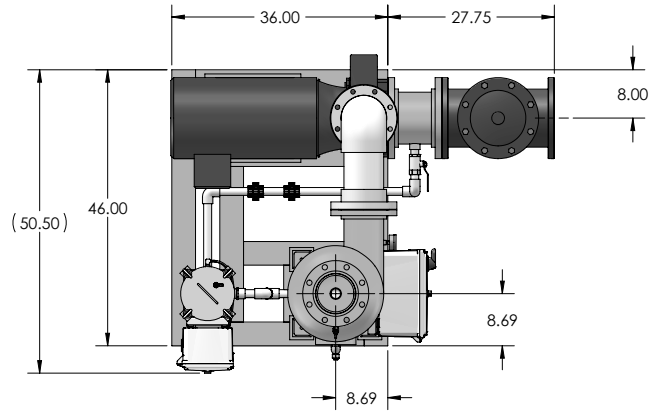

PROPRIETARY AND CONFIDENTIAL THE INFORMATION CONTAINED IN THIS DRAWING IS THE SOLE PROPERTY OF PUROFLUX CORPORATION. ANY REPRODUCTION IN PART OR AS A WHOLE WITHOUT THE WRITTEN PERMISSION OF PUROFLUX CORPORATION IS PROHIBITED.	PF-63-060(B)-DC SEPARATOR PACKAGE 1200 GPM - WITH RECOVERY VESSEL			PUROFLUX CORPORATION
	SIZE C DWG NO. 631-0240	REV C		
DRAWN D. LUNA	RELEASE DATE 05-19-09	SCALE NONE	SHEET 1 OF 1	