

NOTES: UNLESS OTHERWISE SPECIFIED

1. DIMENSIONS MAY VARY - DO NOT USE FOR CONSTRUCTION
2. DIMENSIONS ARE IN INCHES
3. DRAWING IS FOR CONCEPTUAL PURPOSES ONLY
4. ACTUAL COMPONENT SIZING MAY VARY BASED ON DESIGN CONDITIONS
5. ALL CONNECTING PIPING MUST BE SUPPORTED

REVISIONS			
REV	DESCRIPTION	DATE	APPROVED
-			

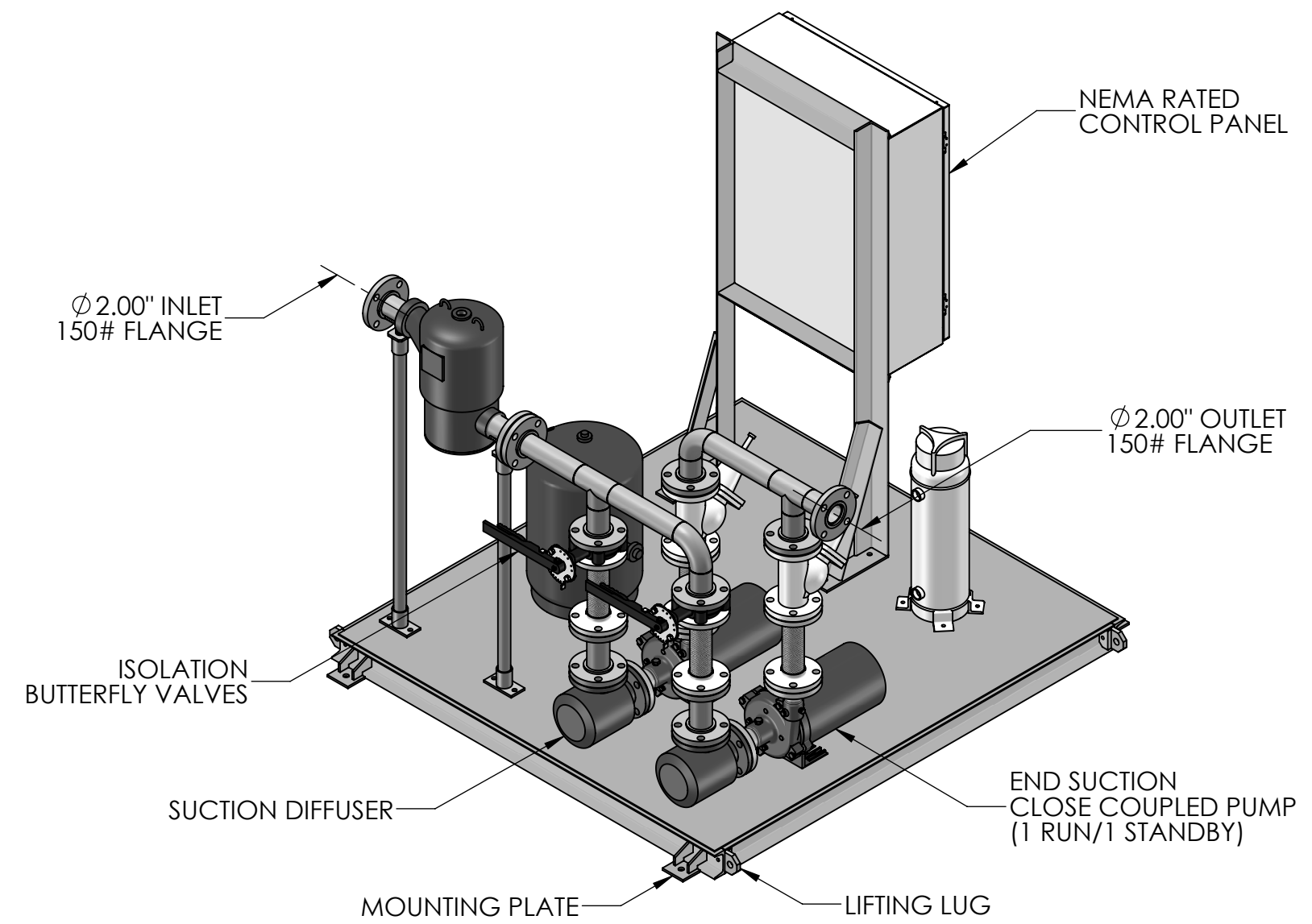
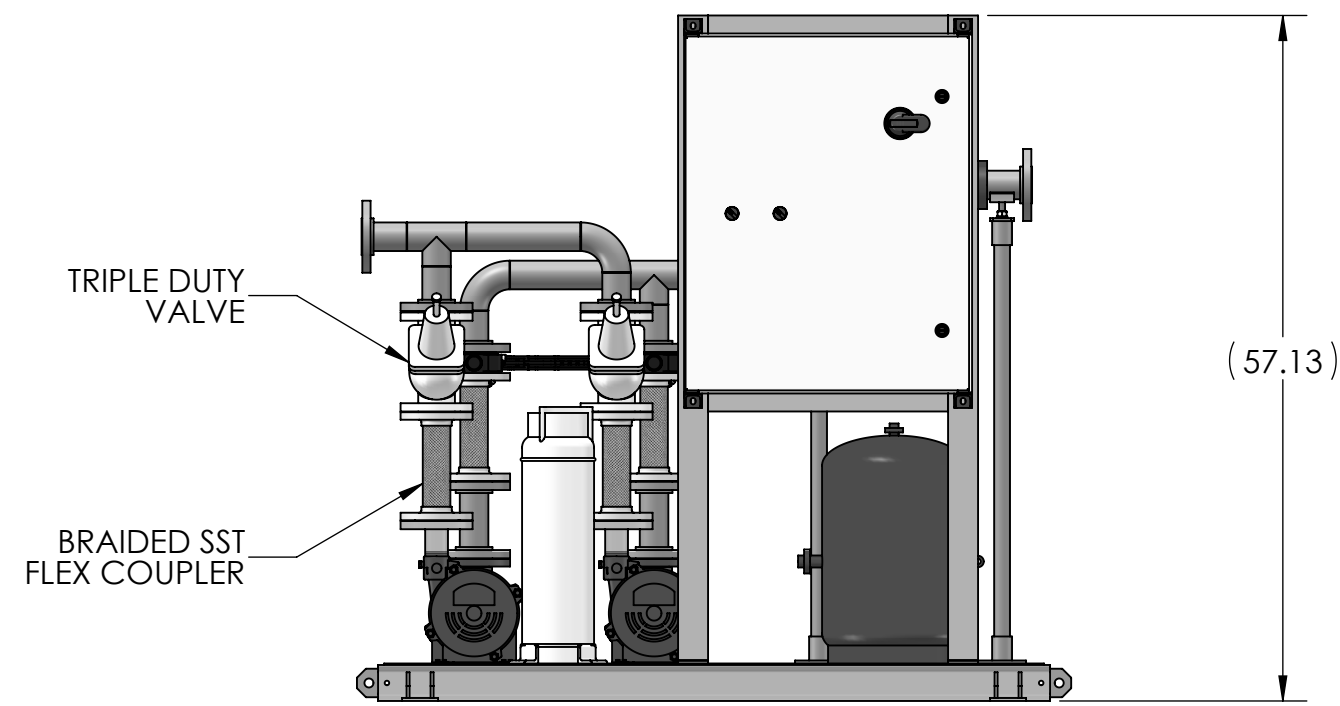
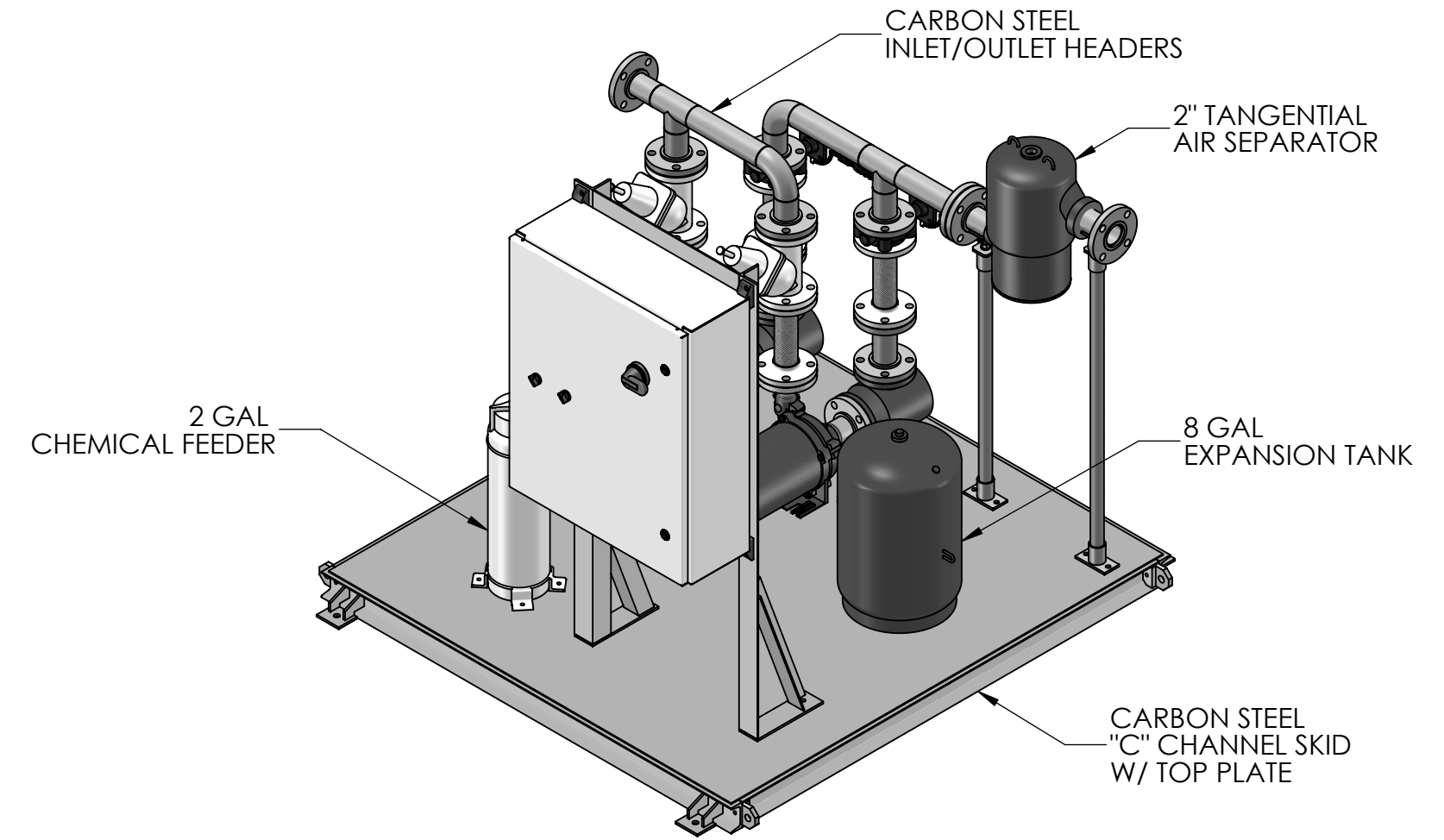
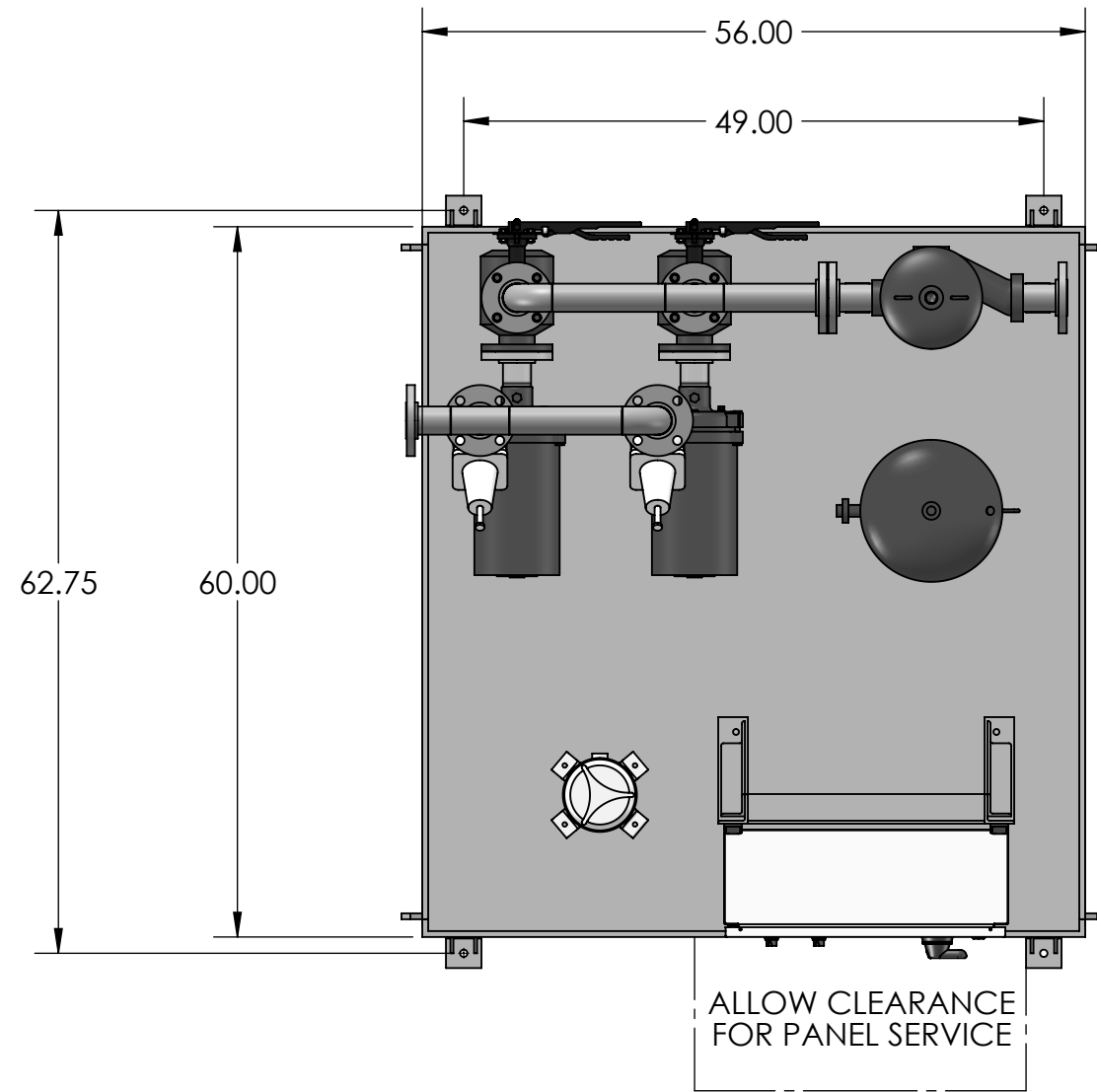

PROPRIETARY AND CONFIDENTIAL THE INFORMATION CONTAINED IN THIS DRAWING IS THE SOLE PROPERTY OF PUROFLUX CORPORATION. ANY REPRODUCTION IN PART OR AS A WHOLE WITHOUT THE WRITTEN PERMISSION OF PUROFLUX CORPORATION IS PROHIBITED.	DUPLEX PUMP PACKAGE 2" PIPE HEADER			
	SIZE DWG NO. C PP1-0336	REV -	PUROFLUX CORPORATION	
	DRAWN S. REICHERT	RELEASE DATE 8-2-19	SCALE NONE	WWW.PUROFLUX.COM
			SHEET 1 OF 1	