

NOTES: UNLESS OTHERWISE SPECIFIED

1. DIMENSIONS MAY VARY - DO NOT USE FOR CONSTRUCTION
2. DIMENSIONS ARE IN INCHES
3. DRAWING IS FOR CONCEPTUAL PURPOSES ONLY
4. ACTUAL COMPONENT SIZING MAY VARY BASED ON DESIGN CONDITIONS
5. ALL CONNECTING PIPING MUST BE SUPPORTED

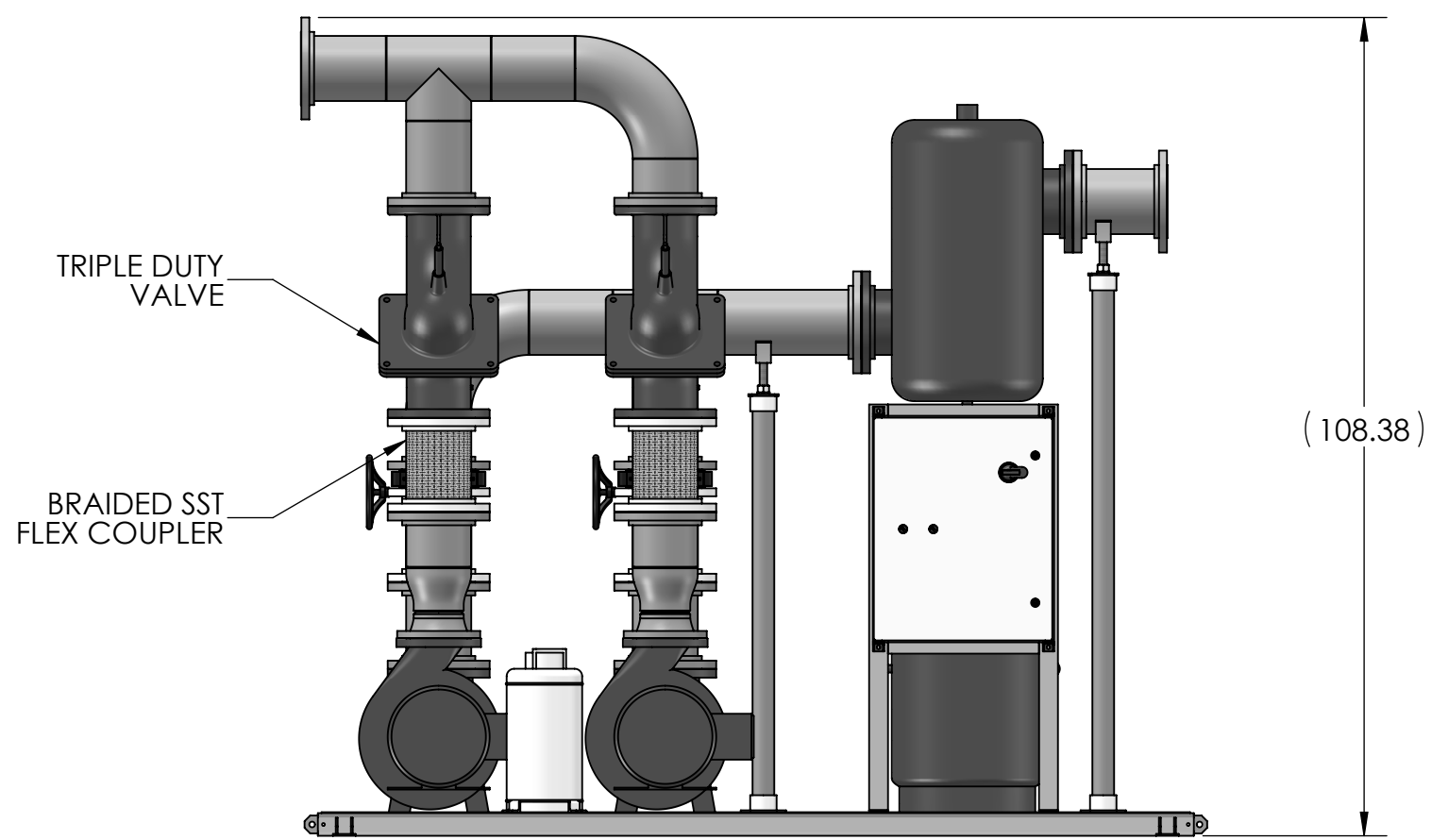

REVISIONS			
REV	DESCRIPTION	DATE	APPROVED
-			

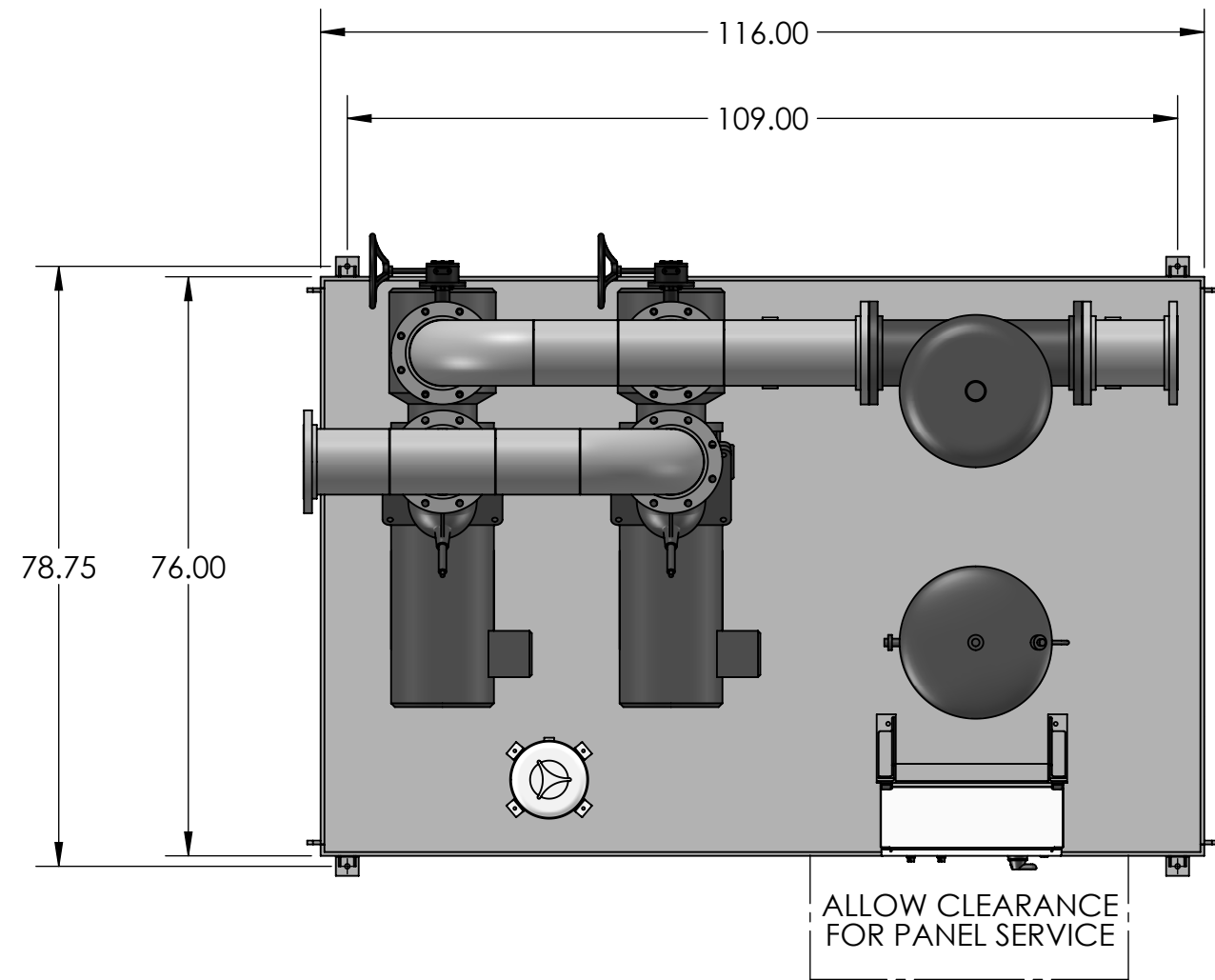
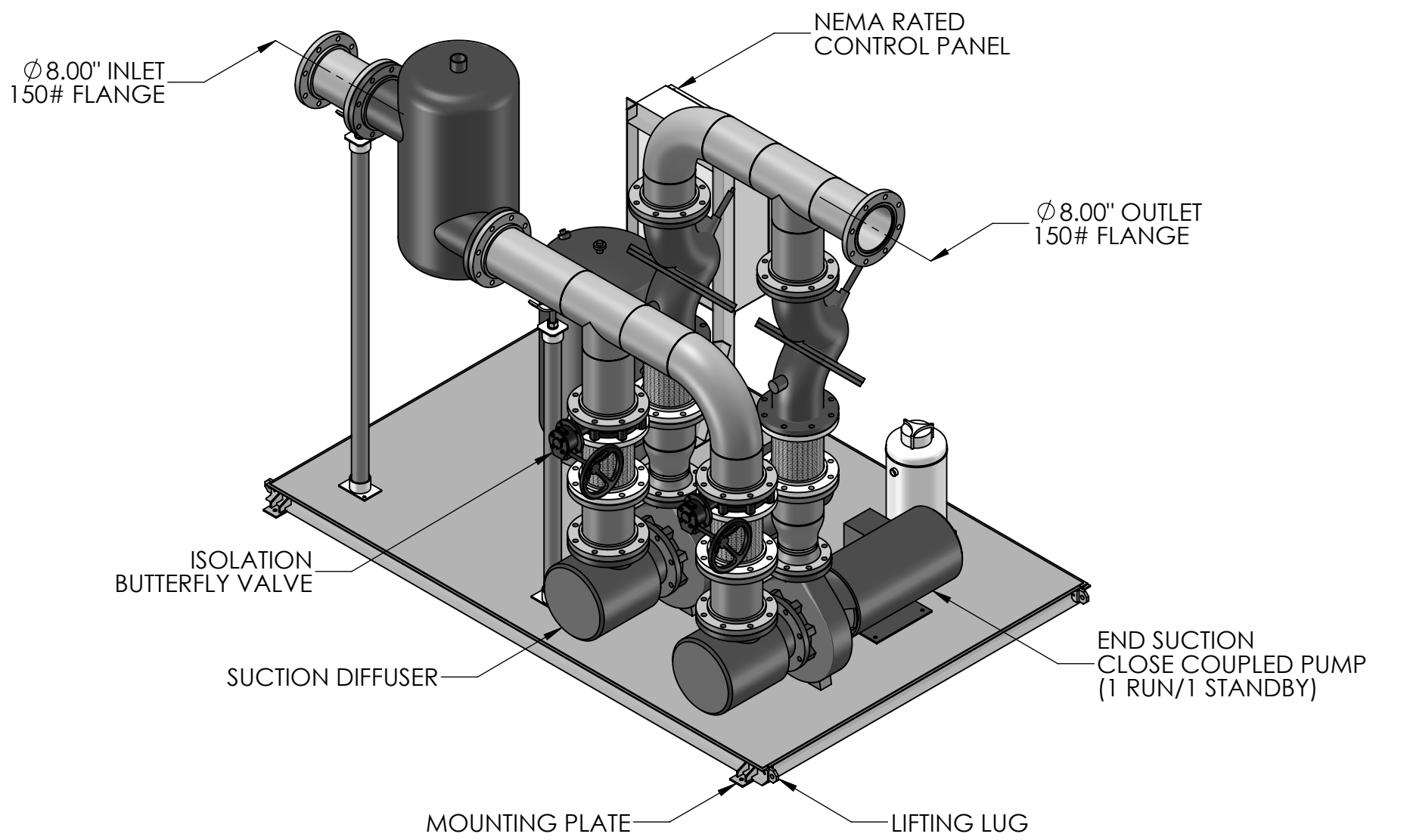
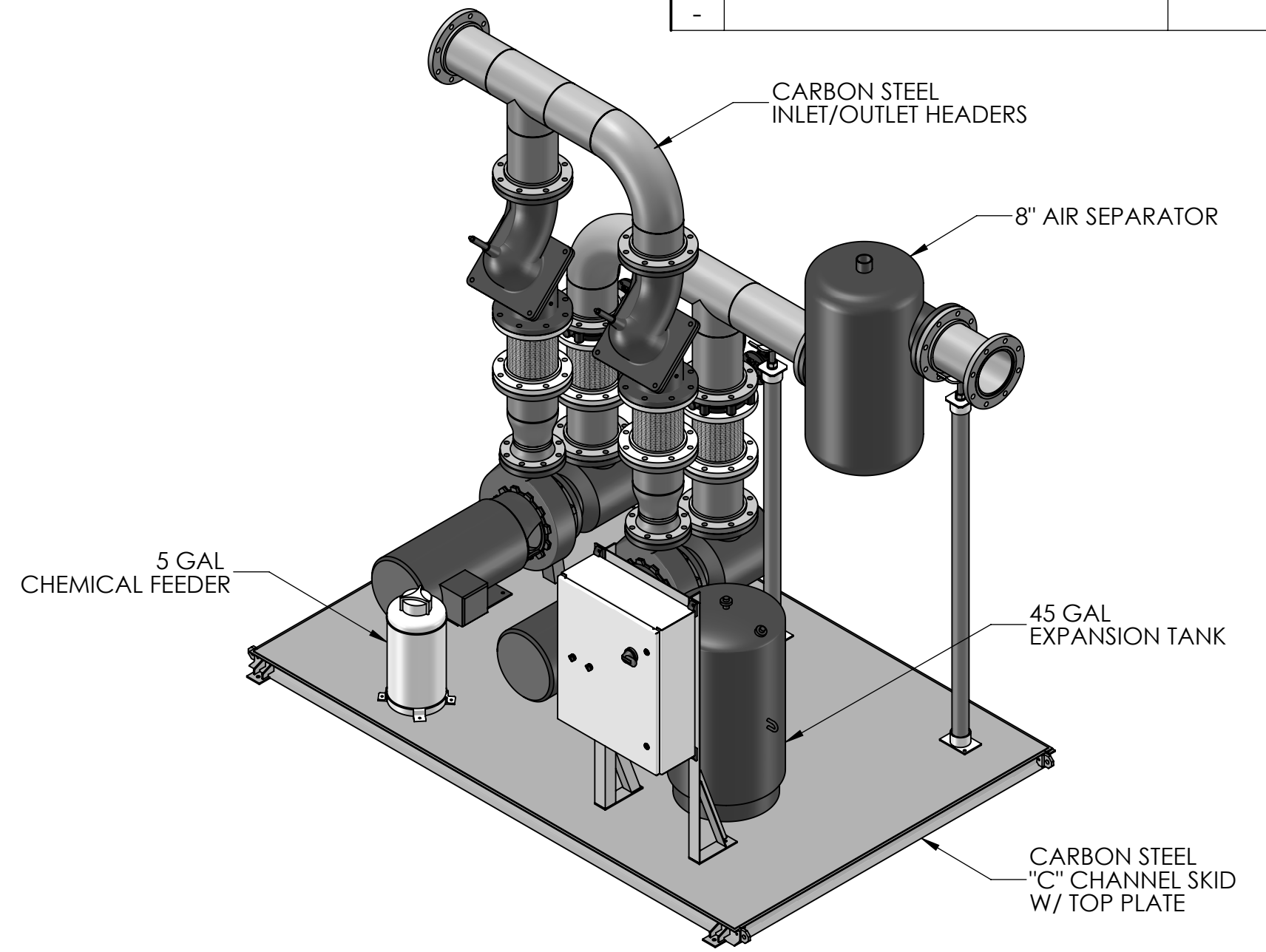

PROPRIETARY AND CONFIDENTIAL THE INFORMATION CONTAINED IN THIS DRAWING IS THE SOLE PROPERTY OF PUROFLUX CORPORATION. ANY REPRODUCTION IN PART OR AS A WHOLE WITHOUT THE WRITTEN PERMISSION OF PUROFLUX CORPORATION IS PROHIBITED.	DUPLEX PUMP PACKAGE 8" PIPE HEADER				
	SIZE C DWG NO. PP1-0340 DRAWN S. REICHERT	REV - RELEASE DATE 8-2-19	SCALE NONE	PUROFLUX CORPORATION WWW.PUROFLUX.COM	
				SHEET 1 OF 1	
	END SUCTION CLOSE COUPLED PUMP (1 RUN/1 STANDBY)				