

## PF-61-080 FLANGED SEPARATOR SPECIFICATION SHEET

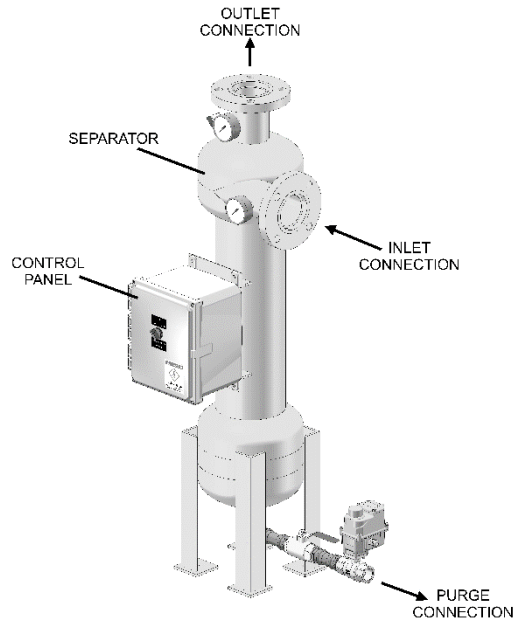

### Features:

- True tangential entry
- 150 psi working pressure
- Five year limited warranty
- Electrically actuated ball valve

### Options:

- Manual purge
- Isolation valve kit
- Wall mounting brackets/legs
- Inspection port

### SYSTEM COMPONENTS

#### Separator :

- Carbon steel construction
- Fusion-bond polyester coated vessel
- Manual air bleed valve
- Inlet/Outlet pressure gauges
- Purge isolation valve

#### Electrical Controls :

- NEMA 4X Enclosure
- Short circuit protection
- Purge selector switch
- Adjustable purge timer
- Electrically actuated ball valve

SPECIFICATIONS	PF-61-080
Flow Range	1170-2355 GPM
System Inlet Connection	8" flange
System Outlet Connection	8" flange
Purge Connection	1-1/2" fpt
Manual Air Bleed Valve	1/4" fpt
Volume	52 GAL
Est. Weight, Dry	570 lbs
Est. Weight, Operating	1002 lbs
Handhole – Inspection/Cleanout	4" x 6"

PRESSURE DROP vs. FLOW RATE							
Pressure Drop	3 psi	4 psi	6 psi	8 psi	10 psi	12 psi	CV Factor
Flow (GPM)	1177	1359	1664	1922	2148	2354	679.4

\*(Flow rate / CV values may vary slightly)

To determine the approximate pressure drop at flow rates not shown in this chart, use the following formula  $\Delta P = (\text{FLOW RATE} / \text{CV})^2$

CV Factor: CV is defined as the flow in gallons per minute (GPM) that will produce a one pound pressure drop across the separator

NOTES: UNLESS OTHERWISE SPECIFIED

1. DIMENSIONS ARE IN INCHES
2. DIMENSIONS MAY VARY SLIGHTLY - DO NOT USE FOR CONSTRUCTION
3. SEPARATOR SYSTEM IS RATED FOR 150 PSI WORKING PRESSURE
4. VESSEL CONSTRUCTION: CARBON STEEL TANK  
EPOXY COATED EXTERIOR

REVISIONS			
REV	DESCRIPTION	DATE	APPROVED
-			

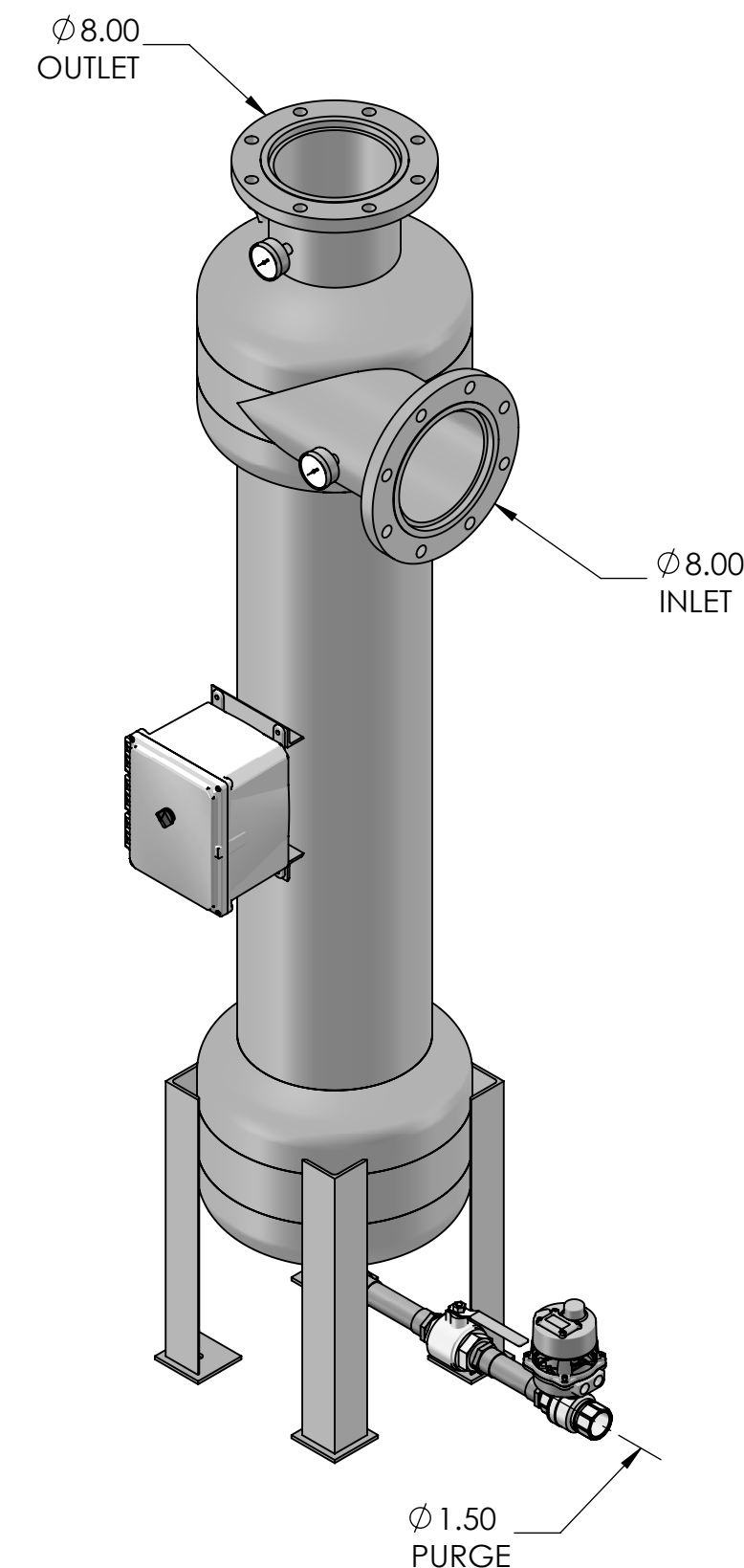
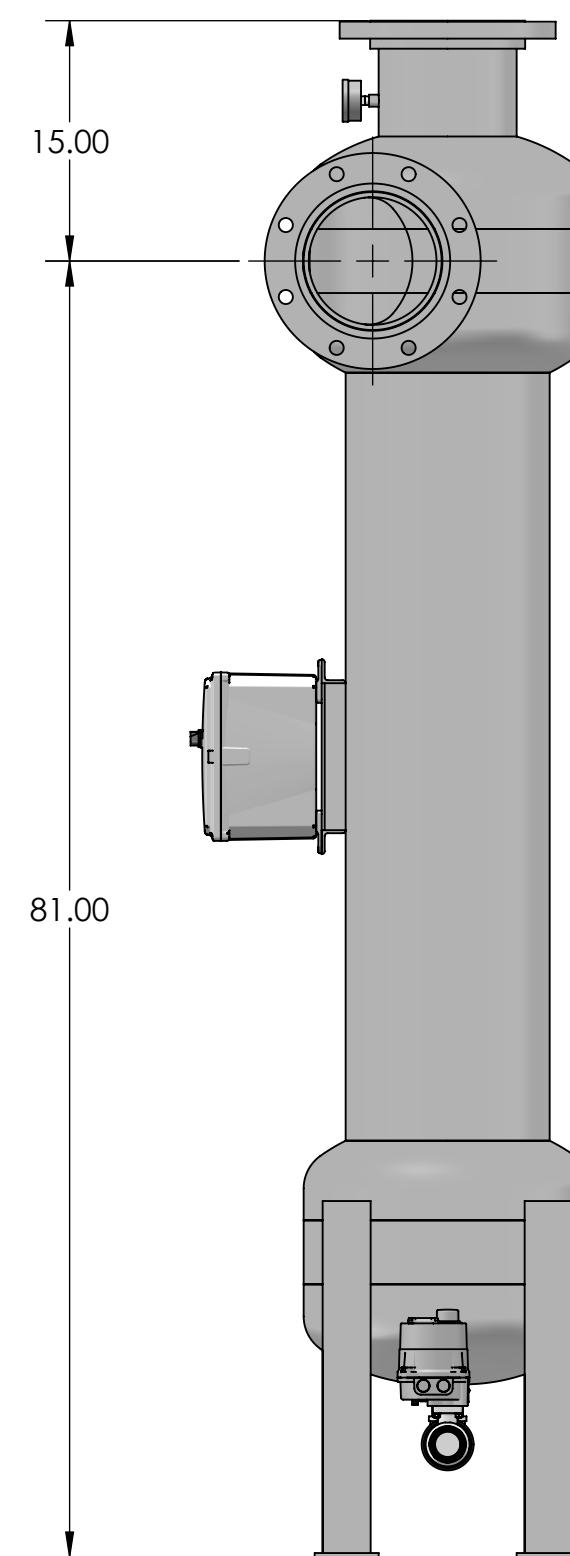
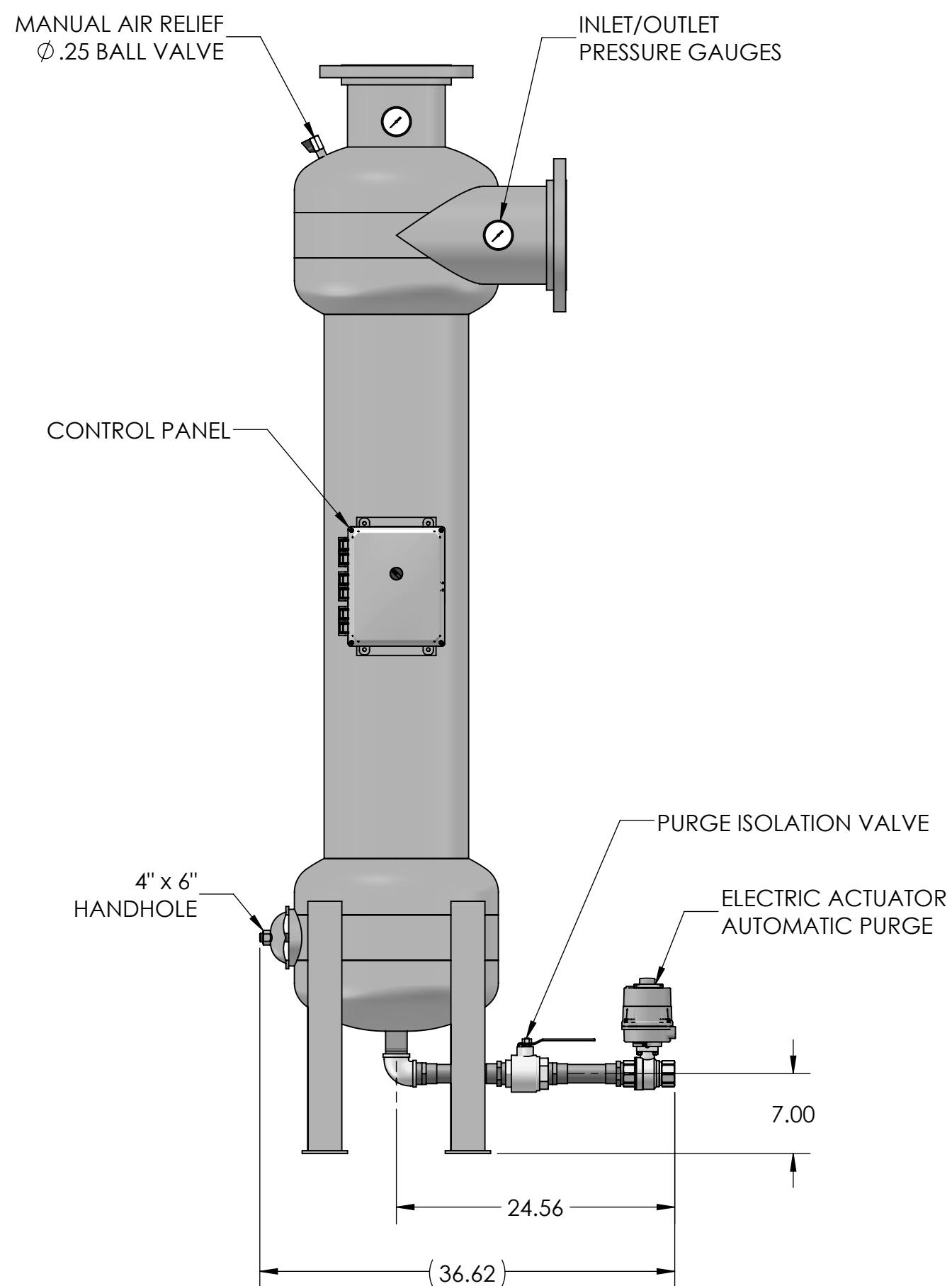
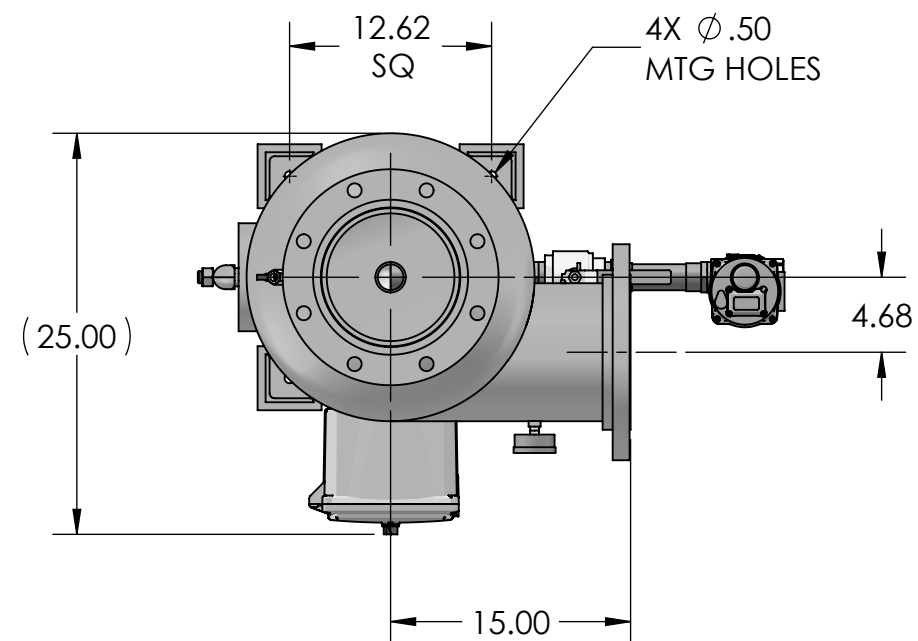

PROPRIETARY AND CONFIDENTIAL THE INFORMATION CONTAINED IN THIS DRAWING IS THE SOLE PROPERTY OF PUROFLUX CORPORATION. ANY REPRODUCTION IN PART OR AS A WHOLE WITHOUT THE WRITTEN PERMISSION OF PUROFLUX CORPORATION IS PROHIBITED.	PF-61-080-AP SEPARATOR 1170-2355 GPM - AUTO PURGE			
	SIZE DWG NO. <b>C</b> 611-0491	REV -	WWW.PUROFLUX.COM	SHEET 1 OF 1
DRAWN F. LOPEZ	RELEASE DATE 10-20-23	SCALE NONE		

4

3

2

1

WARNING !!!!!

THE EXTERNAL HAND WHEEL LOCATED ON THE PURGE ACTUATOR IS ONLY TO BE USED WHEN THERE IS NO POWER TO THE ACTUATOR. DISCONNECT POWER TO THE CONTROL PANEL BEFORE USING THIS FEATURE OR DAMAGE MAY OCCUR TO THE ACTUATOR.

THIS FEATURE IS FOR EMERGENCIES ONLY!

IF VALVE DOES NOT OPEN OR CLOSE FULLY ADJUST ACTUATOR CAMS TO CORRECT THE PROBLEM.

TIMER SETTINGS

THE PUROFLUX AUTO PURGE TIMER IS EQUIPPED WITH CONTROL DIALS TO PROGRAM THE PURGING CYCLES TO MATCH YOUR SPECIFIC NEEDS.

\*\* POWER SHOULD BE TURNED OFF BEFORE CHANGING SETTINGS \*\*

OPERATION MODE

MIDDLE DIAL (MODE) : TIMER OPERATION MODE  
FACTORY SETTING : "D"

CYCLE TIME

LOWER DIAL (T1) : FREQUENCY OF PURGING  
RANGE (1H) : 36 MINUTES TO 30 HOURS  
FACTORY SETTING : EVERY 6 HOURS

PURGING TIME

UPPER DIAL (T2) : DURATION OF PURGING  
RANGE (1S) : 0.6 TO 30 SECONDS  
FACTORY SETTING : 30 SECONDS

REVISIONS			
REV	DESCRIPTION	DATE	APPROVED
A	REVISED TIMER	5-24-16	K.C.

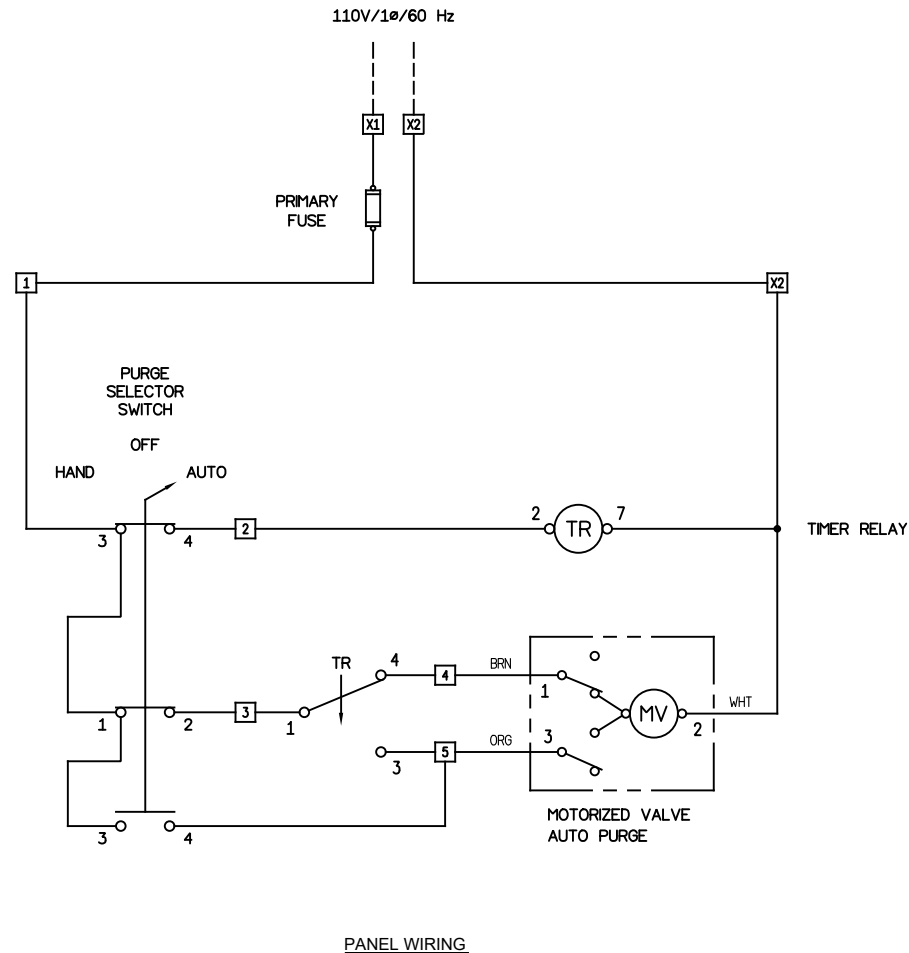

PANEL WIRING

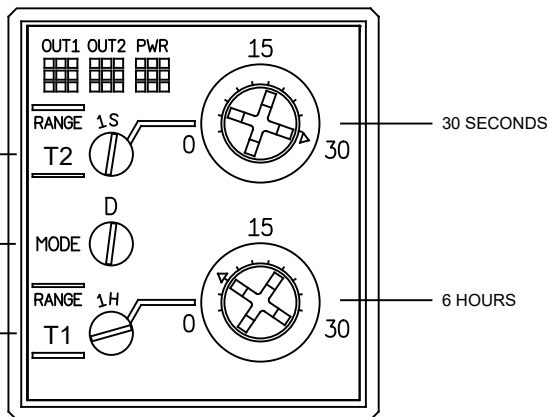

PROPRIETARY AND CONFIDENTIAL THE INFORMATION CONTAINED IN THIS DRAWING IS THE SOLE PROPERTY OF PUROFLUX CORPORATION. ANY REPRODUCTION IN PART OR AS A WHOLE WITHOUT THE WRITTEN PERMISSION OF PUROFLUX CORPORATION IS STRICTLY PROHIBITED.	WIRING DIAGRAM : 120V/1ϕ/60Hz AUTOMATIC PURGE PANEL - IN-LINE		
	SIZE C DRAWN K. CARTER	DWG NO. 612-0046 RELEASE DATE 02-01-02	
WWW.PUROFLUX.COM			SHEET 1 OF 1

4

3

2

1