

PF-64H-040(B)-AP SPECIFICATION SHEET HIGH HEAD PUMP PACKAGE SYSTEM

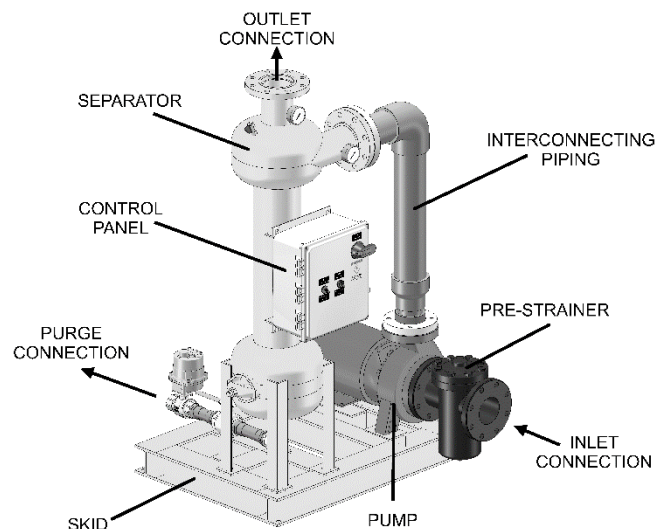

Features:

- Removes particulate as low as 45 microns
- 150 psi working pressure
- Fully assembled skid package
- One year limited warranty

Options:

- Manual purge
- Removable dome separator
- 22-1/2° Profile separator
- Coated carbon steel piping
- Isolation valve kit

SYSTEM COMPONENTS

SPECIFICATIONS	PF-64H-040(B)-AP
Flow Rate	400 GPM
System Inlet Connection	4" Flange
System Outlet Connection	4" Flange
Purge Connection	1-1/2" fpt
Separator Model	PF-61-040
Separator Purge	Automatic
Pump Motor	15 HP
Volume	15 GAL
Est. Weight, Dry	945 lbs
Est. Weight, Operating	1072 lbs

Separator :

- PF-61 Series separator
- Fusion-bond polyester coated vessel
- Manual air bleed valve
- Inlet/Outlet pressure gauges

Pump :

- Centrifugal pump
- TEFC motor
- Cast iron pre-strainer

Skid :

- Fusion-bond polyester coated carbon steel

Electrical Controls :

- UL labeled control panel
- Door disconnect switch
- Motor starter with Short-circuit overload protection
- Local/Off/Remote Switch
- Pump Status/Trip Dry Contact Signals

Automatic Purge :

- Electrically actuated ball valve
- Adjustable purge timer
- Purge Isolation Valve

Interconnecting Pipe :

- Sch.80 PVC piping

NOTES: UNLESS OTHERWISE SPECIFIED

1. DIMENSIONS ARE IN INCHES
2. DIMENSIONS MAY VARY SLIGHTLY - DO NOT USE FOR CONSTRUCTION
3. SEPARATOR SYSTEM IS RATED FOR 150 PSI WORKING PRESSURE

REVISIONS			
REV	DESCRIPTION	DATE	APPROVED
-			

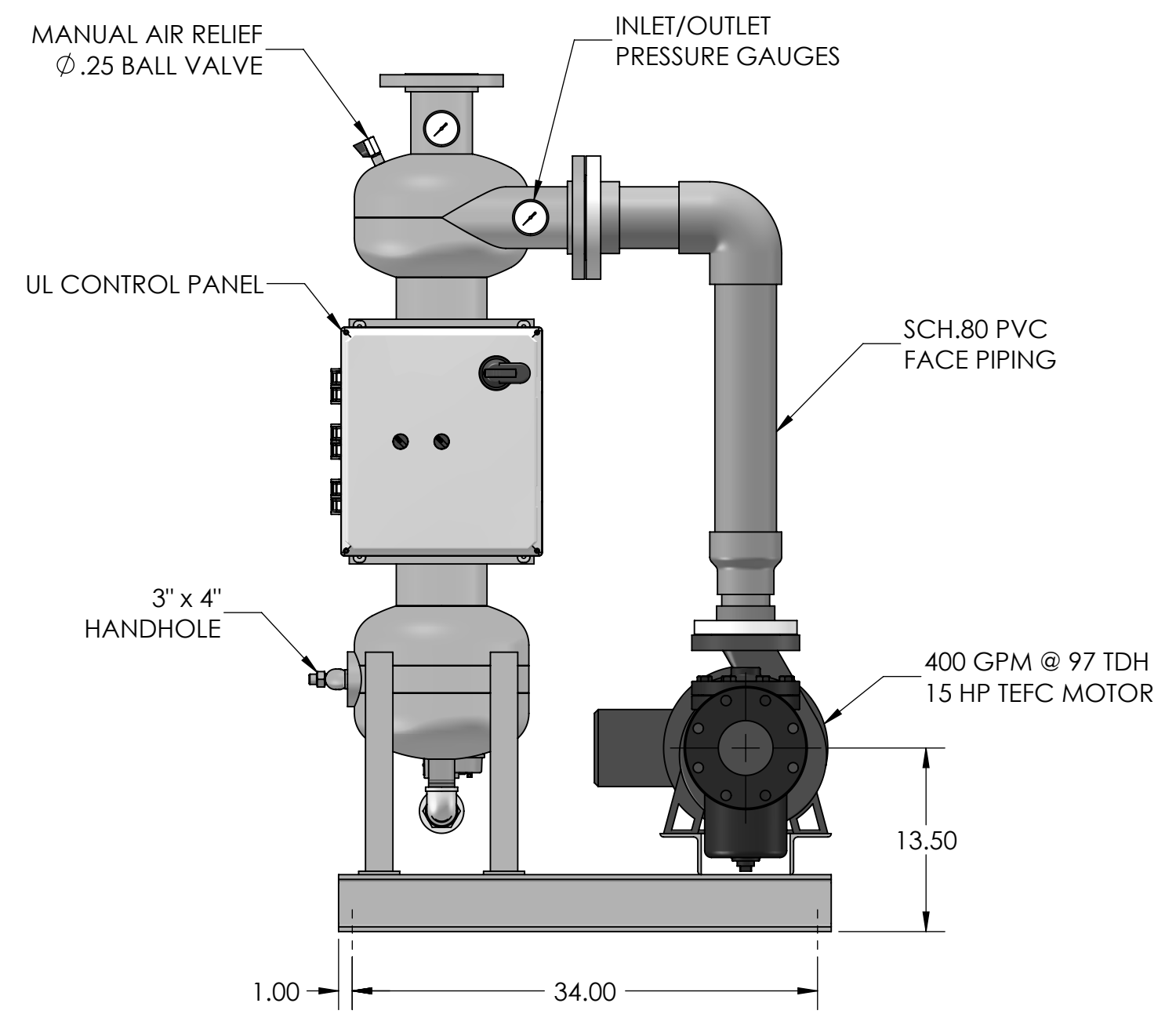
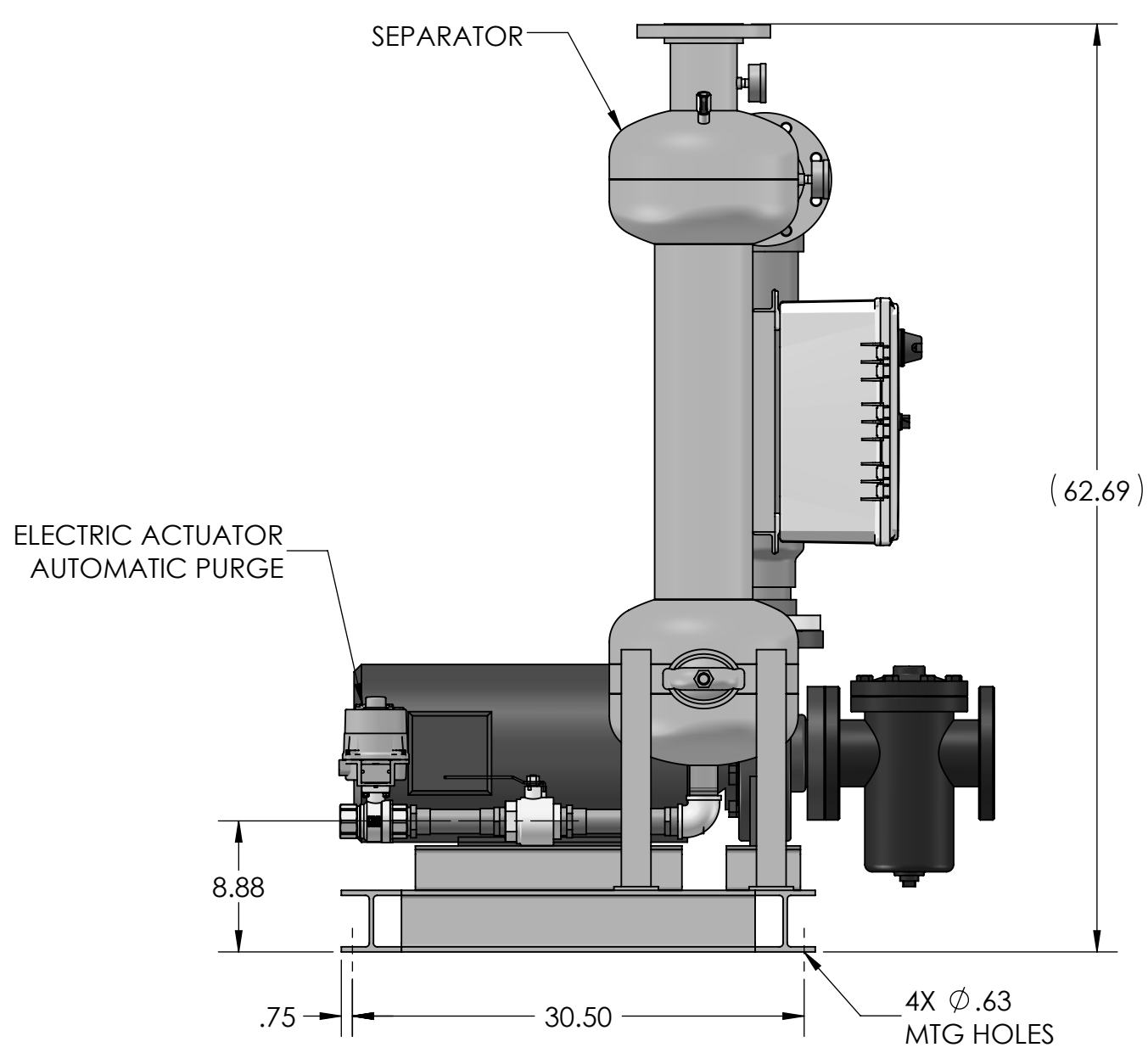
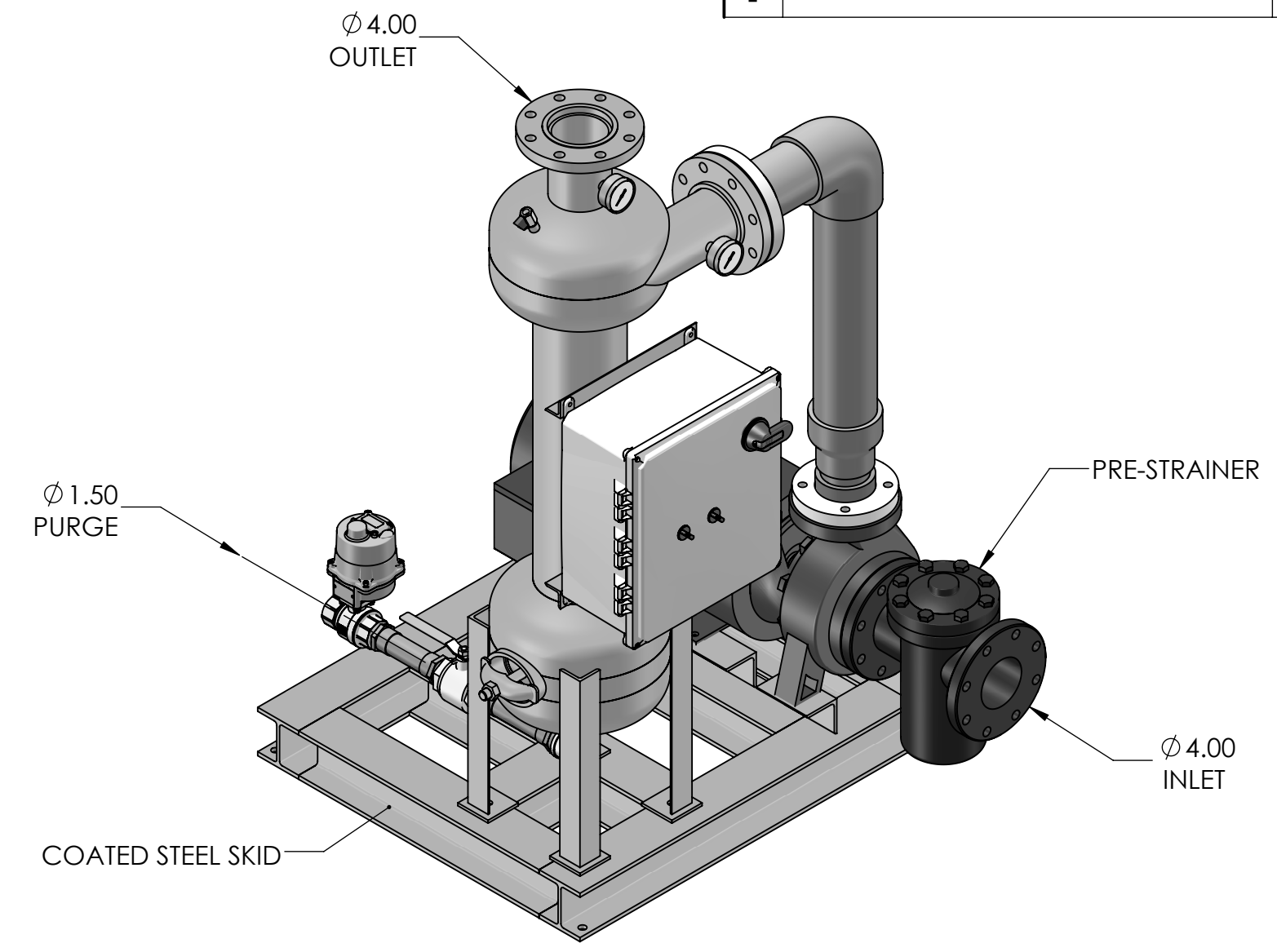
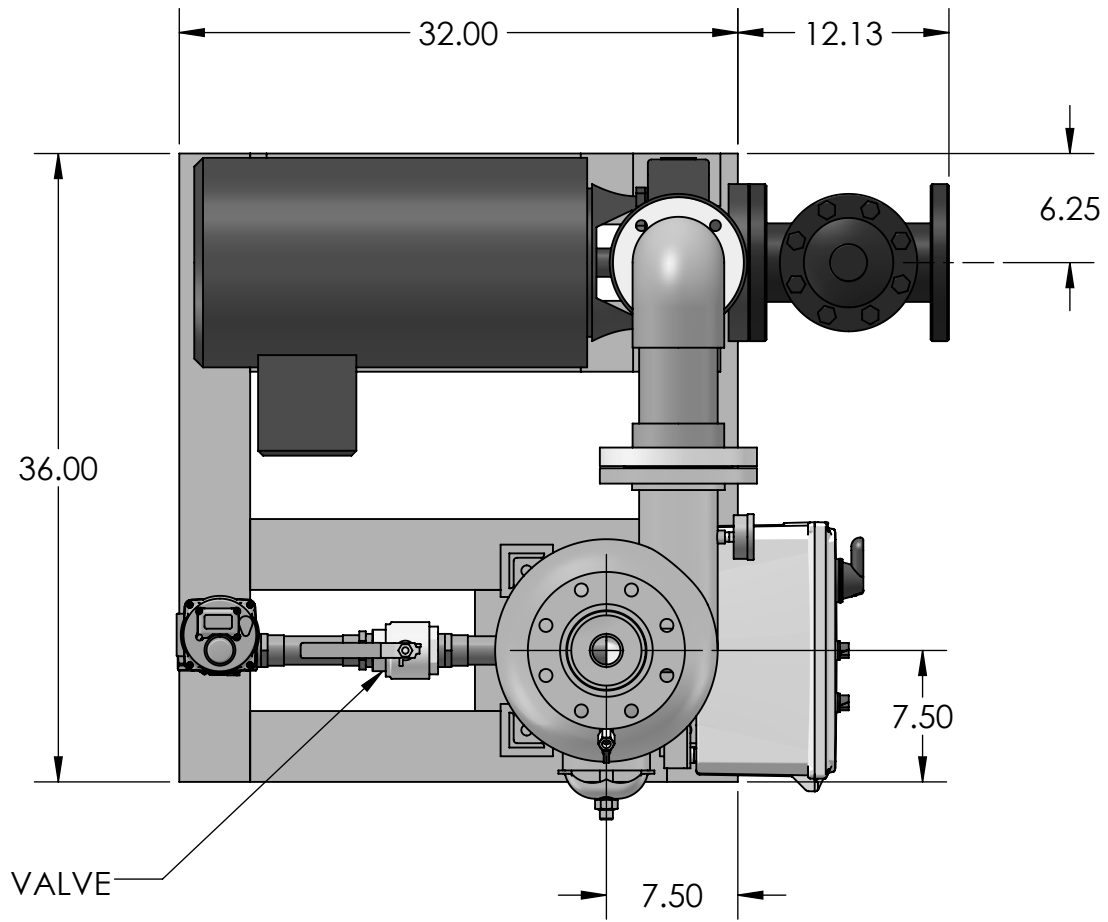

PROPRIETARY AND CONFIDENTIAL THE INFORMATION CONTAINED IN THIS DRAWING IS THE SOLE PROPERTY OF PUROFLUX CORPORATION. ANY REPRODUCTION IN PART OR AS A WHOLE WITHOUT THE WRITTEN PERMISSION OF PUROFLUX CORPORATION IS PROHIBITED.	PF-64H-040(B)-AP HIGH HEAD PACKAGE 400 GPM - W/SKID MOUNTED PUMP		 PUROFLUX CORPORATION WWW.PUROFLUX.COM		
	SIZE DWG NO. C 641-1316	REV -		SHEET 1 OF 1	
	DRAWN F. LOPEZ	RELEASE DATE 3-1-24			SCALE NONE

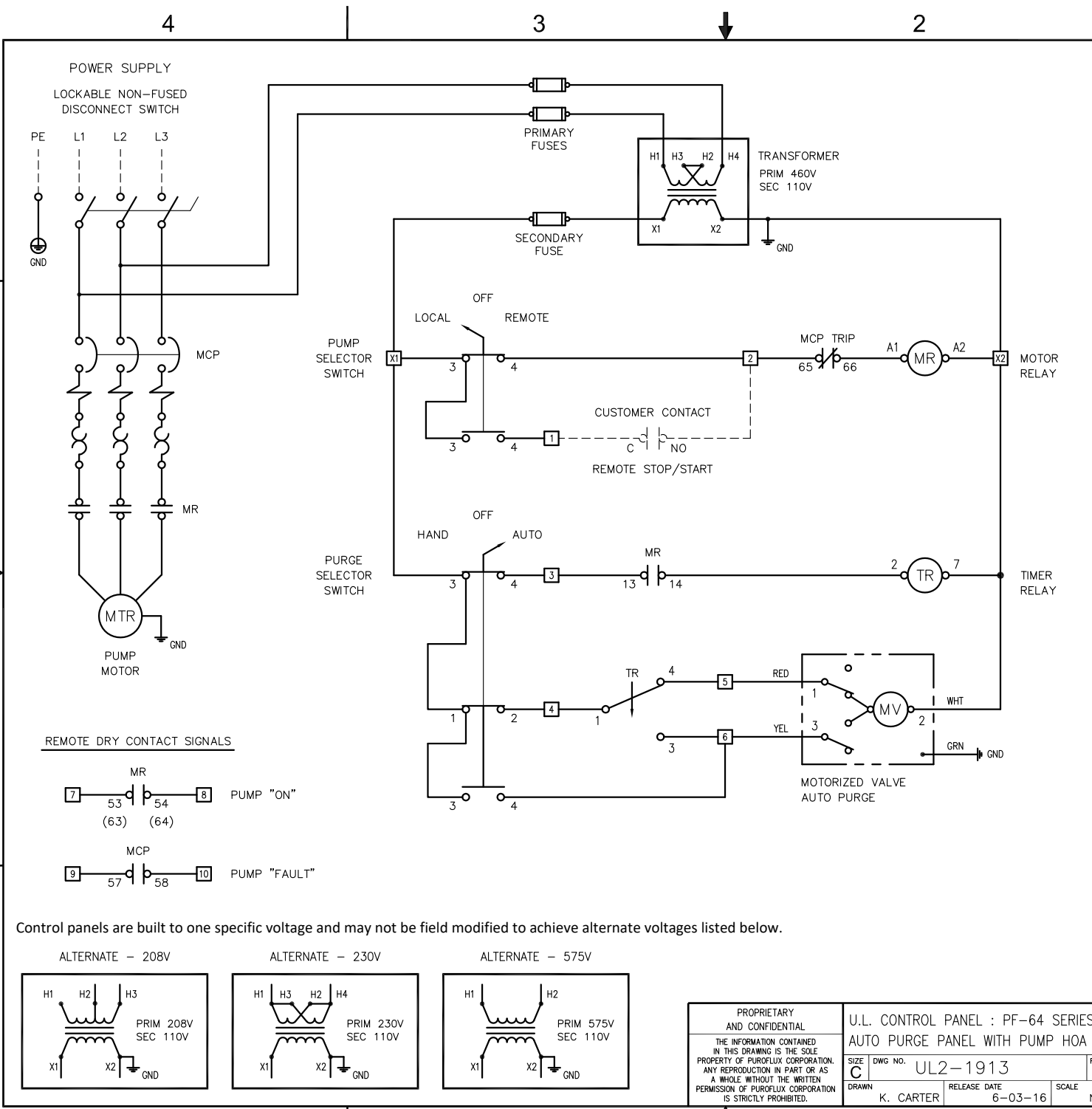

REVISIONS			
REV	DESCRIPTION	DATE	APPROVED

PUMP MOTOR FULL LOAD AMPS (3Ø, 60Hz)				
MOTOR HP	208 VOLTS	230 VOLTS	460 VOLTS	575 VOLTS
1	3.22	2.8	1.4	1.12
2	6.44	5.6	2.8	2.24
3	9.59	8.34	4.17	3.34
5	15.5	13.5	5.76	5.41
7.5	22.4	19.5	9.79	7.81
10	29.2	25.4	12.7	10.1
15	45.1	39.2	19.6	15.7
20	58.9	51.2	25.6	20.5
25	74.5	64.8	32.4	25.9
30	86.9	75.6	37.8	30.2
40	116.0	101.0	50.4	40.3
50	143	130	65	52

FULL LOAD CURRENTS LISTED ABOVE ARE "AVERAGE VALUES" FOR HORSEPOWER RATED MOTORS OF SEVERAL MANUFACTURERS. THE RATED FULL LOAD CURRENT SHOWN ON THE MOTOR NAMEPLATE MAY VARY BY MANUFACTURER.

- NOTES: UNLESS OTHERWISE SPECIFIED
1. BRANCH CIRCUIT PROTECTION SUPPLIED BY OTHERS
 2. PANEL U.L. LISTED AND LABELED
 3. DASHED LINES INDICATE FIELD WIRING
 4. SWITCH OPERATION
 "LOCAL" - REMOTE STOP/START OVERRIDE
 "OFF" - FILTER "OFF"
 "AUTO" - FILTER ON/OFF VIA REMOTE STOP/STOP

ACTUATOR WARNING !!!!

If the valve does not open or close fully adjust actuator using the instructions provided in the Operations & Maintenance manual.

CAUTION - RISK OF ELECTRICAL SHOCK

More than one disconnect switch may be required to de-energize the equipment before servicing.

WARNING - RISK OF FIRE OR ELECTRIC SHOCK

The opening of the branch circuit protective device may be an indication that a fault current has been interrupted. All current carrying parts and other components protected by this device should be examined and replaced if damaged. If burnout of a current element of an overload relay occurs, the complete overload relay must be replaced.

Control panels are built to one specific voltage and may not be field modified to achieve alternate voltages listed below.

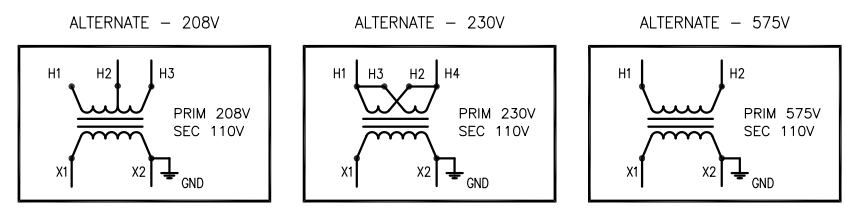

PROPRIETARY AND CONFIDENTIAL THE INFORMATION CONTAINED IN THIS DRAWING IS THE SOLE PROPERTY OF PUROFLUX CORPORATION. ANY REPRODUCTION IN PART OR AS A WHOLE WITHOUT THE WRITTEN PERMISSION OF PUROFLUX CORPORATION IS STRICTLY PROHIBITED.		U.L. CONTROL PANEL : PF-64 SERIES AUTO PURGE PANEL WITH PUMP HOA	
SIZE C DRAWN K. CARTER	DWG NO. UL2-1913 RELEASE DATE 6-03-16	REV C SCALE NONE	WWW.PUROFLUX.COM

WWW.PUROFLUX.COM	SHEET 1 OF 1