

PF-65-040 FLANGED SEPARATOR SPECIFICATION SHEET

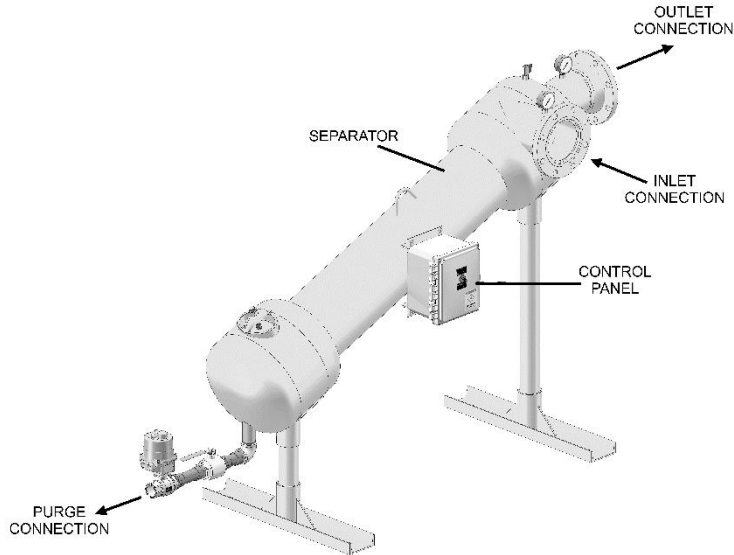

Features:

- True tangential entry
- 150 psi working pressure
- Five year limited warranty
- Electrically actuated ball valve

Options:

- Manual purge
- Isolation valve kit
- Wall mounting brackets/legs
- Inspection port

SYSTEM COMPONENTS

Separator :

- Carbon steel construction
- Fusion-bond polyester coated vessel
- Manual air bleed valve
- Inlet/Outlet pressure gauges
- Purge isolation valve

Electrical Controls :

- NEMA 4X Enclosure
- Short circuit protection
- Purge selector switch
- Adjustable purge timer
- Electrically actuated ball valve

SPECIFICATIONS	PF-61-040
Flow Range	220-440 GPM
System Inlet Connection	4" Flng
System Outlet Connection	4" Flng
Purge Connection	1-1/2" fpt
Manual Air Bleed Valve	1/4" fpt
Volume	12 GAL
Est. Weight, Dry	175 lbs
Est. Weight, Operating	275 lbs
Handhole – Inspection/Cleanout	3" x 4"

PRESSURE DROP vs. FLOW RATE							
Pressure Drop	3 psi	4 psi	6 psi	8 psi	10 psi	12 psi	CV Factor
Flow (GPM)	219	253	309	357	399	438	126.3

*(Flow rate / CV values may vary slightly)

To determine the approximate pressure drop at flow rates not shown in this chart, use the following formula $\Delta P = (\text{FLOW RATE} / \text{CV})^2$

CV Factor: CV is defined as the flow in gallons per minute (GPM) that will produce a one pound pressure drop across the separator

NOTES: UNLESS OTHERWISE SPECIFIED

1. DIMENSIONS ARE IN INCHES
2. DIMENSIONS MAY VARY SLIGHTLY - DO NOT USE FOR CONSTRUCTION
3. SEPARATOR SYSTEM IS RATED FOR 150 PSI WORKING PRESSURE
4. VESSEL CONSTRUCTION: CARBON STEEL TANK
EPOXY COATED EXTERIOR

REVISIONS			
REV	DESCRIPTION	DATE	APPROVED
-			

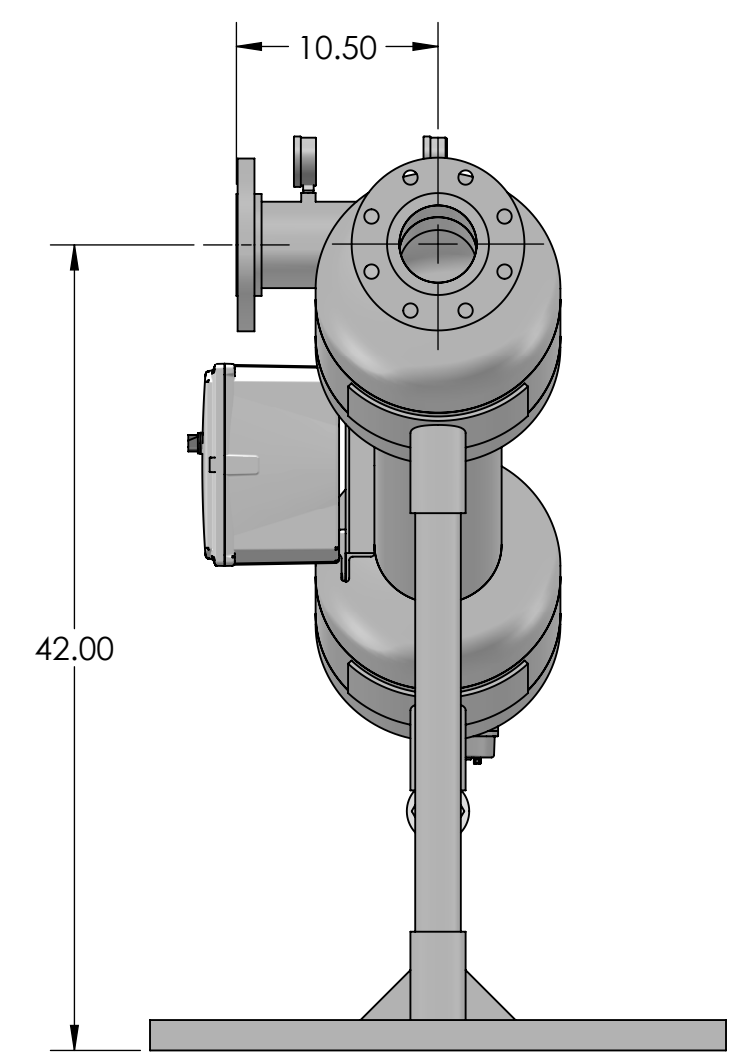
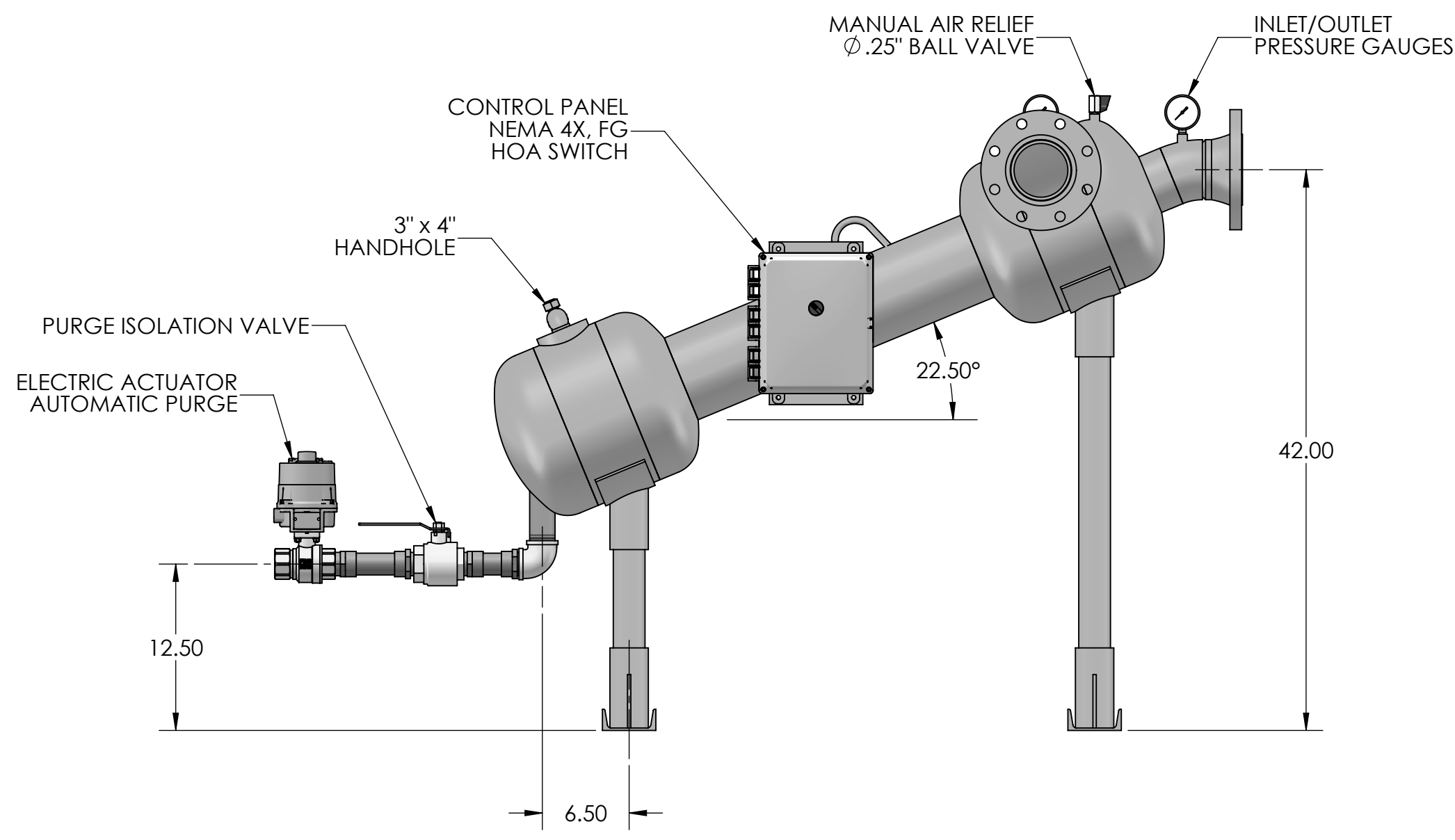
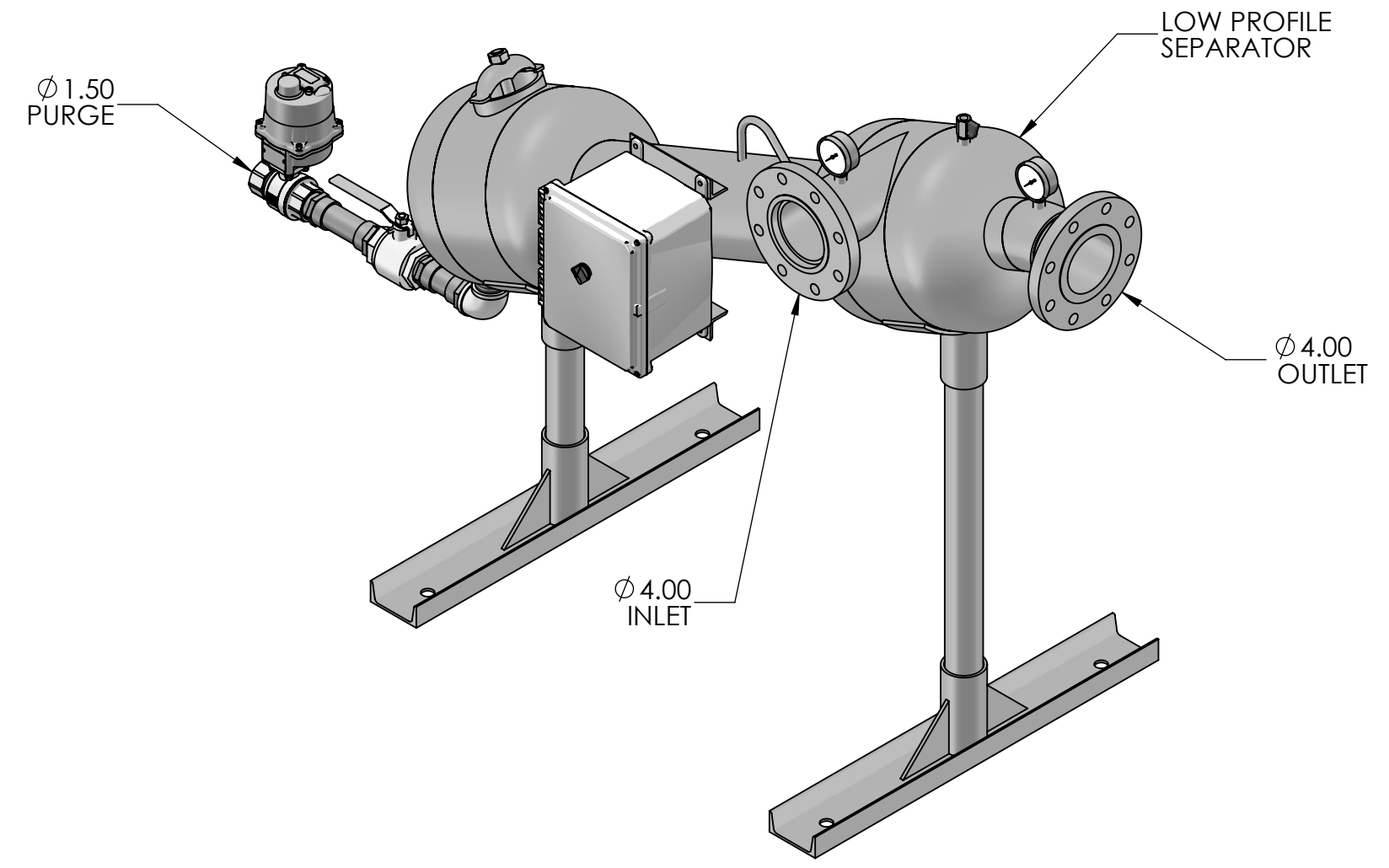
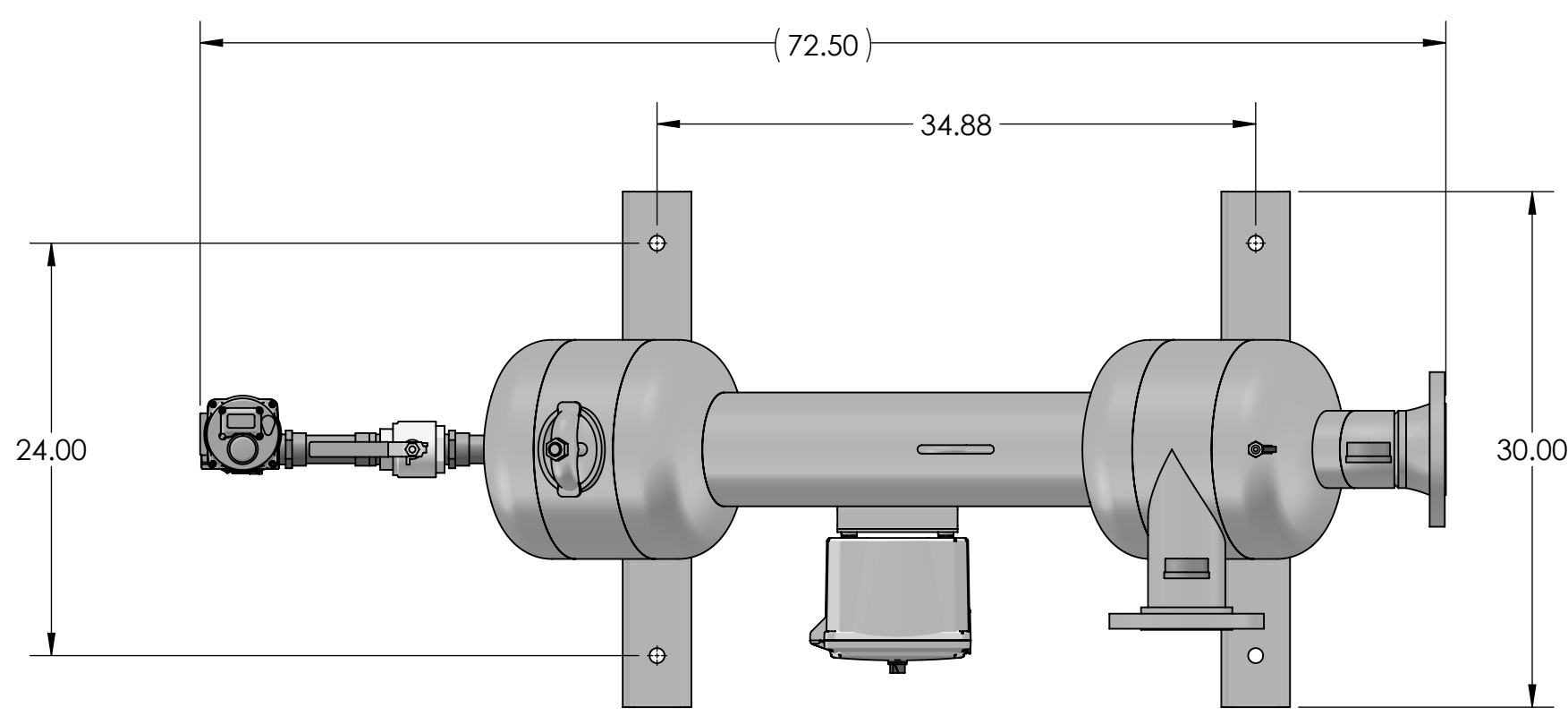

PROPRIETARY AND CONFIDENTIAL THE INFORMATION CONTAINED IN THIS DRAWING IS THE SOLE PROPERTY OF PUROFLUX CORPORATION. ANY REPRODUCTION IN PART OR AS A WHOLE WITHOUT THE WRITTEN PERMISSION OF PUROFLUX CORPORATION IS PROHIBITED.	PF-65-040-AP SEPARATOR 220-440 GPM - 22.5° PROFILE		PUROFLUX CORPORATION	
	SIZE DWG NO. c 651-0140	REV -	WWW.PUROFLUX.COM	
	DRAWN F. LOPEZ	RELEASE DATE 3-14-24	SCALE NONE	SHEET 1 OF 1

4

3

2

1

WARNING !!!!!

THE EXTERNAL HAND WHEEL LOCATED ON THE PURGE ACTUATOR IS ONLY TO BE USED WHEN THERE IS NO POWER TO THE ACTUATOR. DISCONNECT POWER TO THE CONTROL PANEL BEFORE USING THIS FEATURE OR DAMAGE MAY OCCUR TO THE ACTUATOR.

THIS FEATURE IS FOR EMERGENCIES ONLY!

IF VALVE DOES NOT OPEN OR CLOSE FULLY ADJUST ACTUATOR CAMS TO CORRECT THE PROBLEM.

TIMER SETTINGS

THE PUROFLUX AUTO PURGE TIMER IS EQUIPPED WITH CONTROL DIALS TO PROGRAM THE PURGING CYCLES TO MATCH YOUR SPECIFIC NEEDS.

** POWER SHOULD BE TURNED OFF BEFORE CHANGING SETTINGS **

OPERATION MODE

MIDDLE DIAL (MODE) : TIMER OPERATION MODE
FACTORY SETTING : "D"

CYCLE TIME

LOWER DIAL (T1) : FREQUENCY OF PURGING
RANGE (1H) : 36 MINUTES TO 30 HOURS
FACTORY SETTING : EVERY 6 HOURS

PURGING TIME

UPPER DIAL (T2) : DURATION OF PURGING
RANGE (1S) : 0.6 TO 30 SECONDS
FACTORY SETTING : 30 SECONDS

REVISIONS			
REV	DESCRIPTION	DATE	APPROVED
A	REVISED TIMER	5-24-16	K.C.

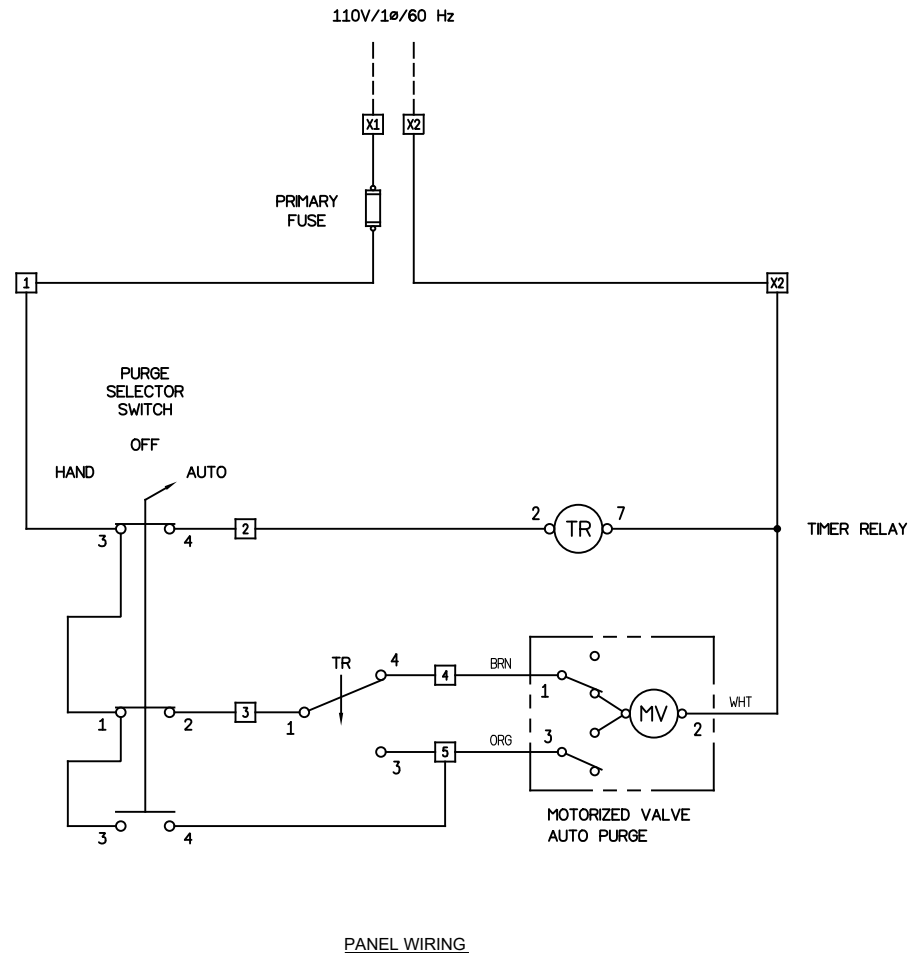

PANEL WIRING

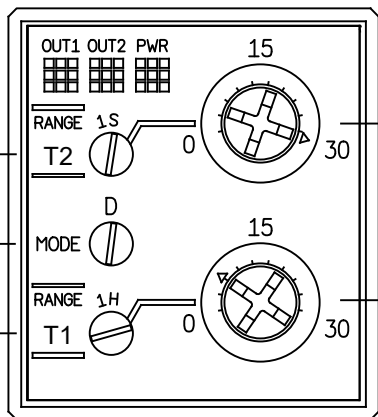

PURGING TIME

30 SECONDS

OPERATION MODE

CYCLE TIME

6 HOURS

PROPRIETARY AND CONFIDENTIAL THE INFORMATION CONTAINED IN THIS DRAWING IS THE SOLE PROPERTY OF PUROFLUX CORPORATION. ANY REPRODUCTION IN PART OR AS A WHOLE WITHOUT THE WRITTEN PERMISSION OF PUROFLUX CORPORATION IS STRICTLY PROHIBITED.	WIRING DIAGRAM : 120V/1ϕ/60Hz AUTOMATIC PURGE PANEL - INLINE		
	SIZE C DRAWN K. CARTER	DWG NO. 612-0046 RELEASE DATE 02-01-02	
WWW.PUROFLUX.COM			SHEET 1 OF 1

4

3

2

1